

TECHNICAL MANUAL
OPERATOR'S AND ORGANIZATIONAL
MAINTENANCE

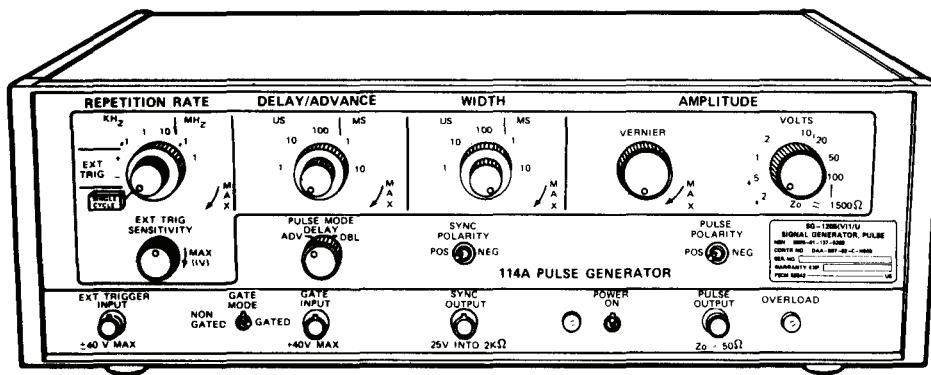

PULSE SIGNAL GENERATOR
SG-1205(V)1/U
(NSN 6625-01-137-5369) (EIC: KML)

EQUIPMENT DESCRIPTION
PAGE 1-2

OPERATOR'S CONTROLS
PAGE 2-1

OPERATOR PMCS
PAGE 2-5

OPERATION
PAGE 2-11

ORGANIZATIONAL PMCS
PAGE 3-2

ORGANIZATIONAL TROUBLESHOOTING
PAGE 3-5

ORGANIZATIONAL MAINTENANCE PROCEDURES
PAGE 3-8

SUBJECT INDEX
PAGE INDEX-1

DISTRIBUTION STATEMENT A – Approved for public release; distribution is unlimited.



5

SAFETY STEPS TO FOLLOW IF SOMEONE IS THE VICTIM OF ELECTRICAL SHOCK:

1

DO NOT TRY TO PULL OR GRAB THE INDIVIDUAL.

2

IF POSSIBLE, TURN OFF THE ELECTRICAL POWER.

3

IF YOU CANNOT TURN OFF THE ELECTRICAL POWER, PULL, PUSH, OR LIFT THE PERSON TO SAFETY USING A DRY WOODEN POLE OR A DRY ROPE OR SOME OTHER INSULATING MATERIAL.

4

SEND FOR HELP AS SOON AS POSSIBLE.

5

AFTER THE INJURED PERSON IS FREE OF CONTACT WITH THE SOURCE OF ELECTRICAL SHOCK, MOVE THE PERSON A SHORT DISTANCE AWAY AND IMMEDIATELY START ARTIFICIAL RESUSCITATION.

WARNING

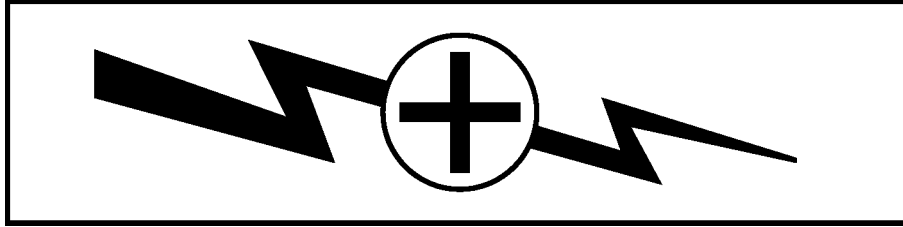

HIGH VOLTAGE

is used in the operation of this equipment.

DEATH ON CONTACT

may result if personnel fail to observe safety precautions.

Never work on electronic equipment unless there is another person nearby who is familiar with the operation and hazards of the equipment and who is competent in administering first aid. When technicians are aided by operators, they must warn them about dangerous areas.

A periodic review of safety precautions in TB 385-4, Safety Requirements for Maintenance of Electrical and Electronic Equipment, is recommended. When the equipment is operated with covers removed, DO NOT TOUCH exposed connections or components. MAKE CERTAIN you are not grounded when making connections or adjusting components inside the test instrument.

Be careful not to contact high-voltage connections of 115-volt ac input when installing or operating this equipment.

Whenever the nature of the operation permits, keep one hand away from the equipment to reduce the hazard of current flowing through vital organs of the body.

WARNING

Do not be misled by the terms "LOW VOLTAGE."
Potentials as low as 50 volts can cause death under certain conditions.

First Aid, refer to FM 4-25.11.

WARNING

POISONOUS FUMES

Fumes of ISOPROPYL ALCOHOL are poisonous. Provide thorough ventilation whenever used; do not breathe the fumes. Do not use near open flame or hot surface.

CHANGE }
No. 2 }

Headquarters
Department of the Army
Washington, D.C., 2 January 2007

OPERATOR'S AND ORGANIZATIONAL MAINTENANCE MANUAL
FOR
PULSE SIGNAL GENERATOR
SG-1205(V)1/U
(NSN 6625-01-137-5369) (EIC: KML)

DISTRIBUTION STATEMENT A – Approved for public release; distribution is unlimited.

TM 11-6625-3050-12, dated 5 December 1983, is changed as follows:

1. Remove old pages and insert new pages as indicated below.
2. New or changed text is indicated by a vertical bar in the outer margin of the page.
3. Added illustrations are indicated by a vertical bar adjacent to the illustration identification number. Changed illustrations are indicated by a miniature pointing hand adjacent to the updated area and a vertical bar adjacent to the illustration identification number.

Remove Pages

A/(B blank)
i and ii
iii/iv
(v blank)/1-0
Cover

Insert Pages

A/(B blank)
i and ii
iii/1-0
None
Cover

4. File this change sheet in front of the publication for reference purposes.

By Order of the Secretary of the Army:

Official:

JOYCE E. MORROW
Administrative Assistant to the
Secretary of the Army
0631901

PETER J. SCHOOMAKER
General, United States Army
Chief of Staff

DISTRIBUTION:

To be distributed in accordance with the Initial Distribution Number (IDN) 366741, requirements for TM 11-6625-3050-12.

CHANGE }
No. 1 }

Headquarters
Department of the Army
Washington, D.C., 2 October 2006

**OPERATOR'S AND ORGANIZATIONAL MAINTENANCE MANUAL
FOR
PULSE SIGNAL GENERATOR
SG-1205(V)1/U
(NSN 6625-01-137-5369) (EIC: KML)**

HAZARDOUS MATERIAL INFORMATION – This document has been reviewed for the presence of solvents containing hazardous materials as defined by the EPCRA 302 and 313 lists by the Engineering, Environmental, and Logistics Oversight Office. As of the base document, dated 5 December 1983, all references to solvents containing hazardous materials have been removed from this document by substitution with non-hazardous or less-hazardous materials where possible.

OZONE DEPLETING CHEMICAL INFORMATION – This document has been reviewed for the presence of Class I ozone depleting chemicals by the Engineering, Environmental, and Logistics Oversight Office. As of the base document, dated 5 December 1983, all references to Class I ozone depleting chemicals have been removed from this document by substitution with chemicals that do not cause atmospheric ozone depletion.

WARNING – This document contains technical data whose export is restricted by the Arms Export Control Act (Title 22, U. S. C., Sec 2751 et seq) or the Export Administration Act 1979, as amended, Title 50, U.S.C., App. 2401 et seq.. Violations of these export laws are subject to severe criminal penalties. Disseminate in accordance with provisions of DOD Directive 5230.25.

DISTRIBUTION STATEMENT A – Approved for public release; distribution is unlimited.

TM 11-6625-3050-12, dated 5 December 1983, is changed as follows:

1. Remove old pages and insert new pages as indicated below.
2. New or changed text is indicated by a vertical bar in the outer margin of the page.
3. Added illustrations are indicated by a vertical bar adjacent to the illustration identification number. Changed illustrations are indicated by a miniature pointing hand adjacent to the updated area and a vertical bar adjacent to the illustration identification number.

Remove Pages

A and B
None
i and ii

Insert Pages

a through c/(d blank)
A/(B blank)
i and ii

Remove Pages

1-1 and 1-2
2-7 and 2-8
2-13 through 2-17/(2-18 blank)
3-1 through 3-4
3-11 and 3-12
A-1/(A-2 blank)
E-1 and E-2
DA Forms 2028-2
Cover

Insert Pages

1-1 and 1-2
2-7 and 2-8
2-13 through 2-17/(2-18 blank)
3-1 through 3-4
3-11 and 3-12
A-1/(A-2 blank)
E-1 and E-2
DA Forms 2028
Cover

4. File this change sheet in front of the publication for reference purposes.

By Order of the Secretary of the Army:

Official:

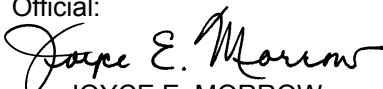
JOYCE E. MORROW
*Administrative Assistant to the
Secretary of the Army*
0624003

PETER J. SCHOOMAKER
*General, United States Army
Chief of Staff*

DISTRIBUTION:

To be distributed in accordance with the Initial Distribution Number (IDN) 366741,
requirements for TM 11-6625-3050-12.

INSERT LATEST CHANGED PAGES. DESTROY SUPERSEDED PAGES.

LIST OF EFFECTIVE PAGES

NOTE

ON CHANGED PAGES, THE PORTION OF THE TEXT AFFECTED BY THE LATEST CHANGE IS INDICATED BY A VERTICAL LINE OR OTHER CHANGE SYMBOL IN THE OUTER MARGIN OF THE PAGE.

Date of issue for original and changed pages are:
 Original 0 5 December 1983
 Change 1 2 October 2006
 Change 2 2 January 2007

Total number of pages in this publication is 83 consisting of the following:

Page No.	* Change No.	Page No.	*Change No.
Cover.....	2	3-3	0
a through c.....	1	3-4	1
d blank	1	3-5 through 3-11	0
A.....	2	3-12	1
B blank.....	2	3-13	0
i and ii.....	2	3-14 blank.....	0
iii and 1-0	2	A-1	1
1-1 and 1-2.....	1	A-2 blank	1
1-3 through 1-6.....	0	B-1 through B-6	0
2-1 and 2-6.....	0	C (Not Applicable)	0
2-7	1	D (Not Applicable)	0
2-8 through 2-13.....	0	E-1	1
2-14 and 2-15.....	1	E-2 blank	1
2-16	0	Glossary-1	0
2-17	1	Glossary-2 blank	0
2-18 blank.....	1	Index-1 through Index-3	0
3-1	0	Index-4 blank.....	0
3-2.....	1		

* Zero in this column indicates an original page.

TECHNICAL MANUAL
NO. 11-6625-3050-12



HEADQUARTERS
DEPARTMENT OF THE ARMY
WASHINGTON, D.C., 05 December 1983

OPERATOR'S AND ORGANIZATIONAL MAINTENANCE MANUAL
FOR
PULSE SIGNAL GENERATOR
SG-1205(V)1/U
(NSN 6625-01-137-5369) (EIC: KML)

REPORTING ERRORS AND RECOMMENDING IMPROVEMENTS

You can help improve this manual. If you find any mistakes or if you know of a way to improve the procedures, please let us know. Mail your letter or DA Form 2028 (Recommended Changes to Publications and Blank Forms) directly to: Commander, U. S. Army Aviation and Missile Command, AMSAM-MMC-MA-NP, Redstone Arsenal, AL 35898-5000. A reply will be furnished to you. You may also provide DA Form 2028 information to AMCOM via email, fax or the World Wide Web. Our fax number is: DSN 788-6546 or Commercial 256-842-6546. Our email address is: 2028@redstone.army.mil. Instructions for sending an electronic 2028 may be found at the back of this manual immediately preceding the hardcopy 2028. For the World Wide Web use: <https://amcom2028.redstone.army.mil>.

DISTRIBUTION STATEMENT A – Approved for public release; distribution is unlimited.

TABLE OF CONTENTS

		Page
HOW TO USE THIS MANUAL		iii
CHAPTER 1	INTRODUCTION	1-1
Section I	General Information.....	1-1
Section II	Equipment Description	1-2
Section III	Technical Principles of Operation	1-5
CHAPTER 2	OPERATING INSTRUCTIONS	2-1
Section I	Description and Use of Operator's Controls and Indicators.....	2-1
Section II	Operator Preventive Maintenance Checks and Services (PMCS).....	2-5
Section III	Operation Under Usual Conditions	2-11
Section IV	Operation Under Unusual Conditions	2-17
CHAPTER 3	ORGANIZATIONAL MAINTENANCE	3-1
Section I	Repair Parts, Special Tools; Test, Measurement, and Diagnostic Equipment (TMDE); and Support Equipment.....	3-1
Section II	Service Upon Receipt.....	3-2
Section III	Preventive Maintenance Checks and Services (PMCS).....	3-2
Section IV	Troubleshooting.....	3-5
Section V	Maintenance Procedures	3-8
Section VI	Preparation for Storage or Shipment	3-13

TABLE OF CONTENTS - Continued

Page

APPENDIX A	REFERENCES.....	A-1
B	MAINTENANCE ALLOCATION CHART (MAC).....	B-1
C	COMPONENTS OF END ITEM AND BASIC ISSUE ITEMS LIST (Not Applicable).....	C-1
D	ADDITIONAL AUTHORIZATION LIST (Not Applicable).....	D-1
E	EXPENDABLE SUPPLIES AND MATERIALS LIST	E-1
	GLOSSARY	GLOSSARY-1
	INDEX.....	INDEX-1

HOW TO USE THIS MANUAL

This manual tells you about your Pulse Signal Generator, SG-1205(V)1/U, and contains instructions about how to use it.

When you first receive your Pulse Signal Generator, SG-1205(V)1/U, start at the front of the manual and go all the way through to the back, and become familiar with every part of the manual and the Pulse Signal Generator, SG-1205(V)1/U.

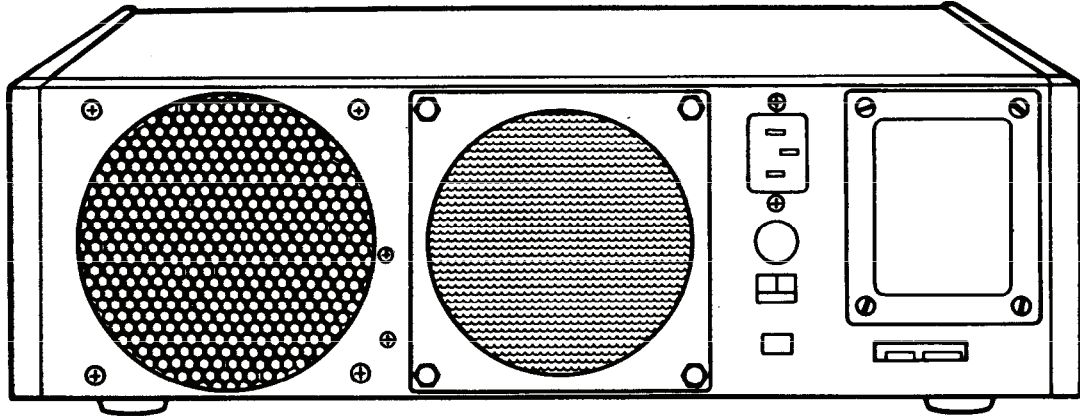

EL8ZT003

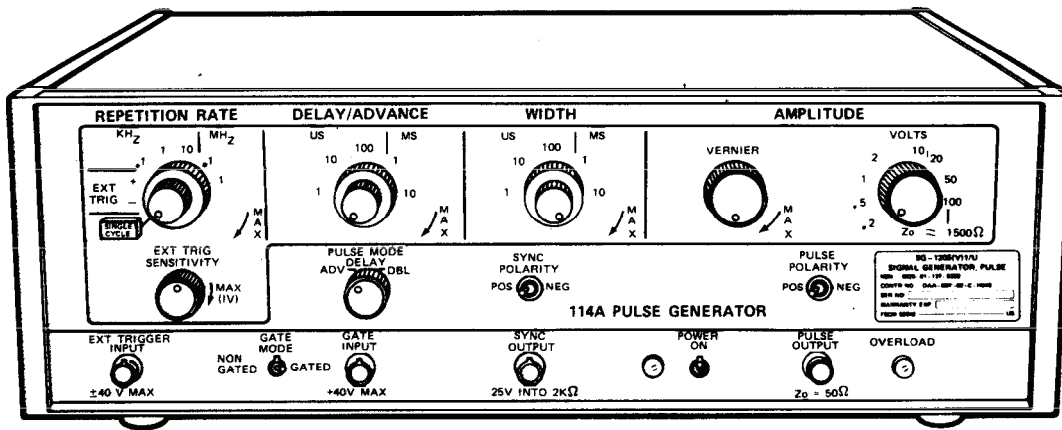

EL8ZT003

Figure 1-1. Pulse Signal Generator

**CHAPTER 1
INTRODUCTION**

	Para	Page
Consolidated Index of Army Publications and Blank Forms	1-2	1-1
Destruction of Army Materiel to Prevent Enemy Use	1-4	1-2
Equipment Characteristics, Capabilities, and Features	1-10	1-2
Equipment Data	1-12	1-4
Location and Description of Major Components	1-11	1-3
Maintenance Forms, Records, and Reports	1-3	1-1
Nomenclature Cross-Reference List.....	1-9	1-2
Preparation for Storage or Shipment	1-5	1-2
Quality Assurance/Quality Control (QA/QC).....	1-6	1-2
Reporting Equipment Improvement Recommendations (EIR).....	1-7	1-2
Safety, Care, and Handling	1-13	1-5
Scope	1-1	1-1
Technical Principles of Operation		1-5
Warranty Information.....	1-8	1-2

Section I. GENERAL INFORMATION

1-1. SCOPE.

This manual contains operation and maintenance instructions for Pulse Signal Generator SG-1205(V)1/U. This manual includes procedures for operation, cleaning, inspection, testing, servicing, disassembly, and assembly of the equipment as authorized for operator and organizational maintenance.

1-2. CONSOLIDATED INDEX OF ARMY PUBLICATIONS AND BLANK FORMS.

Refer to the latest issue of DA Pam 25-30 to determine whether there are new editions, changes, or additional publications pertaining to the equipment.

1-3. MAINTENANCE FORMS, RECORDS, AND REPORTS.

a. Reports of Maintenance and Unsatisfactory Equipment. Department of the Army forms and procedures used for equipment maintenance will be those prescribed by DA Pam 750-8, The Army Maintenance Management System (TAMMS) Users Manual.

b. Reporting of Packaging and Handling Discrepancies. Fill out and forward SF 364, (Report of Discrepancy (ROD)) as prescribed in AR 735-11-2/DLAI 4140.55/SECNAVINST 4355.18A/AFJMAN 23-215.

c. Transportation and Discrepancy Report (TDR) (SF 361). Fill out and forward a Transportation Discrepancy Report (TDR) (SF 361) as prescribed in DA Pam 25-30.

1-4. DESTRUCTION OF ARMY MATERIEL TO PREVENT ENEMY USE.

Destruction of Army materiel to prevent enemy use shall be in accordance with TM 750-244-2.

1-5. PREPARATION FOR STORAGE OR SHIPMENT.

Preparation instructions for storage and shipment are found in Chapter 3, section VI.

1-6. QUALITY ASSURANCE/QUALITY CONTROL (QA/QC).

Maintenance standards for Pulse Signal Generator SG-1205(V)1/U are given in the operator preventive maintenance section and the organizational maintenance chapter of this manual. By performing PMCS and the maintenance procedures, quality control of the equipment will be maintained.

1-7. REPORTING EQUIPMENT IMPROVEMENT RECOMMENDATIONS (EIR).

If your signal generator needs improvement, let us know. Send us an EIR. You, the user, are the only one who can tell us what you don't like about your equipment. Let us know why you don't like the design or performance. Put it on an SF 368 (Product Quality Deficiency Report). Mail it to us at: Commander, US Army Aviation and Missile Command, ATTN: AMSAM-MMC-MA-NM, Redstone Arsenal, Alabama 35898-5000. We'll send you a reply.

1-8. WARRANTY.

The signal generator is warranted by Systron Donner Corporation for 12 months. Warranty starts on the date of shipment to the original buyer. Report all defects in material or workmanship to your supervisor who will take appropriate action.

1-9. NOMENCLATURE CROSS-REFERENCE LIST.

Common names will be used when major components of the signal generator are mentioned in this manual.

NOTE

Official nomenclature must be used when filling out report forms or looking up Technical Manuals.

Common Nomenclature

Signal Generator

Official Nomenclature

Pulse Signal Generator SG-1205(V)1/U

Section II. EQUIPMENT DESCRIPTION

1-10. EQUIPMENT CHARACTERISTICS, CAPABILITIES, AND FEATURES.

- Provides high power I-MHz signal generation.
- Pulse duration specified down to 50 ns, allowing for low duty cycle applications.
- Pulse repetition rate, delay/advance, width, and amplitude are all front panel selectable.

1-11. LOCATION AND DESCRIPTION OF MAJOR COMPONENTS.

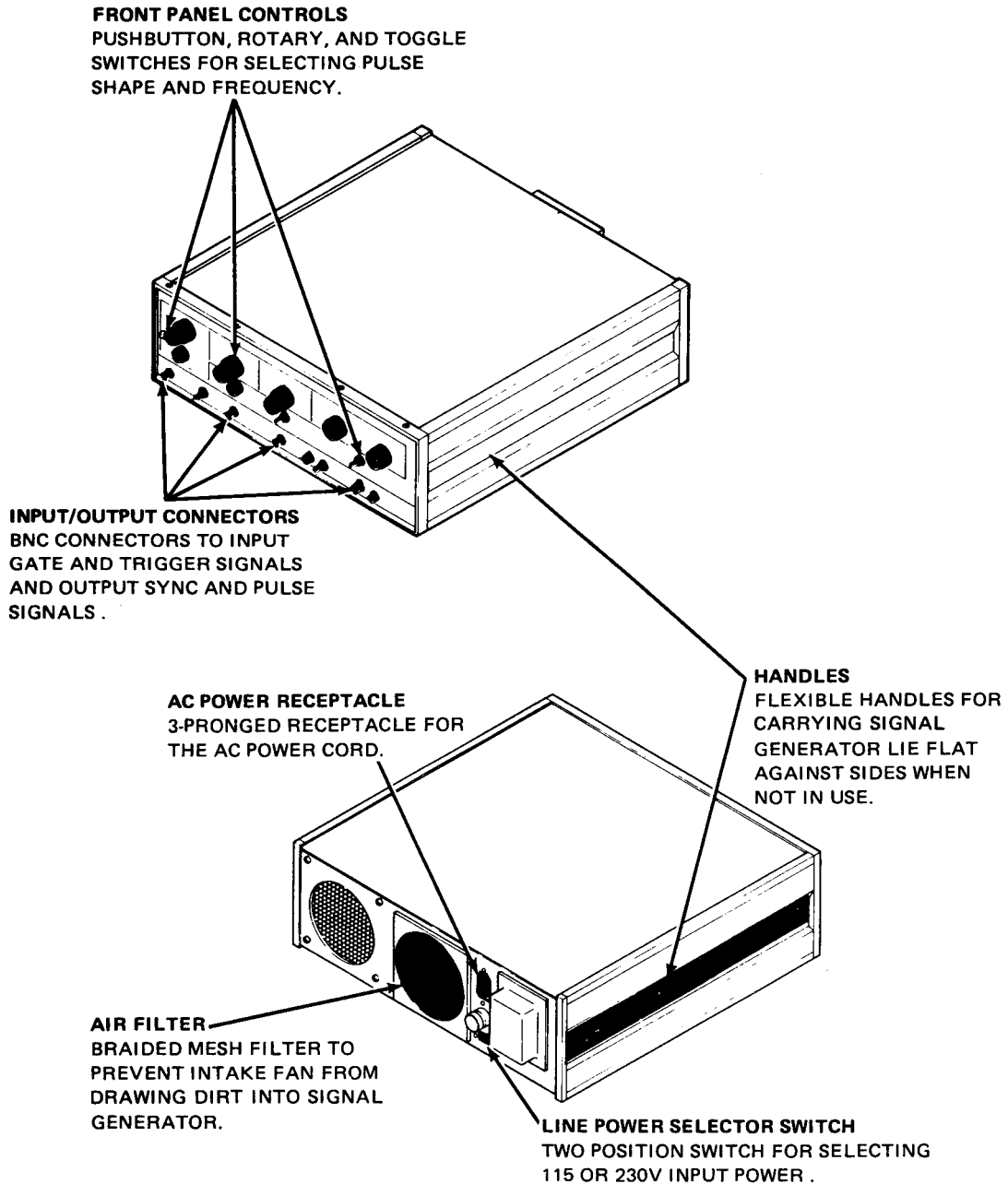

EL8ZT004

1-12. EQUIPMENT DATA.

WEIGHT AND DIMENSIONS

Weight:

Net:	25 lb (11.4 kg)
Shipping:	28 lb (12.7 kg)

Dimensions:

Height:	5.25 in. (13.33 cm)
Width:	16.75 in. (42.54 cm)
Depth:	17.00 in. (43.18 cm)

OPERATING CHARACTERISTICS

Power:	100 to 125/200 to 250 V ac, 50 to 60 Hz, = 250 W. Selectable by rear panel switch and multitap transformer.
--------	--

Operating Temperature:	32° to 122° F (0° to 50° C)
------------------------	-----------------------------

PERFORMANCE CHARACTERISTICS

Repetition Rate:	10 Hz to 1 MHz, continuously variable, switch selected in five ranges with overlapping vernier control. (Maximum rate for double pulse generation is 500 kHz).
------------------	--

Output Pulse Amplitude:	80 mV to 100V (into 50 Ω) continuously variable, switch selected in nine ranges with overlapping vernier control.
-------------------------	---

Transition Times:	Fixed \leq 13 ns for amplitude of up to 50 V, \pm 17 ns for amplitude from 50 to 100 V.
-------------------	---

Jitter:

Repetition rate:	0.5%
Delay/advance:	0.1%
Duration jitter:	0.1%

Pulse Duration (Width):	50 ns to 10 ms, continuously variable; switch selected in five ranges with overlapping vernier control.
-------------------------	---

Duty Factor:	Maximum duty factor (cycle) is 50% for amplitudes of up to 20 V and 10% for amplitudes from 20 to 100 v.
--------------	--

Aberrations (at maximum vernier):

Ringings:	6%
Overshoot:	6%
Preshoot:	6%
Droop:	6%
Fourth Corner Overshoot, 100-V Range:	<8%

Sync Output Pulse:

Amplitude:	≈ 25 V into 2 kΩ (polarity selectable)
Duration:	≈ 100 ns
Transition Time:	
Rise:	<50 ns
Fall:	<300 ns

1-13. SAFETY, CARE, AND HANDLING.

Observe all **WARNINGS**, **CAUTIONS**, and **NOTES** in this manual. This equipment can be extremely dangerous if these instructions are not followed.

Section III. TECHNICAL PRINCIPLES OF OPERATION

Pulse Signal Generator SG-1205(V)1/U (see figure 1-2) produces high power 10-HZ to 1-MHz output pulses. A second synchronizing (sync) pulse is also provided.

- ① The front panel contains all the controls for selecting output pulse parameters. It also contains two indicators to show power on and overload conditions. Two input connectors are provided, one for an external trigger signal and one for a gate signal. Two output connectors provide the main output pulses and the sync pulses.
- ② The internal circuitry generates the main output pulses and the sync pulses. The settings of the front panel controls determine the amplitude, width, polarity, and other parameters of the pulses. An internal power supply provides all the voltages needed by the other internal circuits.
- ③ The rear panel contains the input connector for input power, a fuse, and a switch for selecting 115- or 230-V ac input power. A fan is also provided for cooling the internal circuitry.

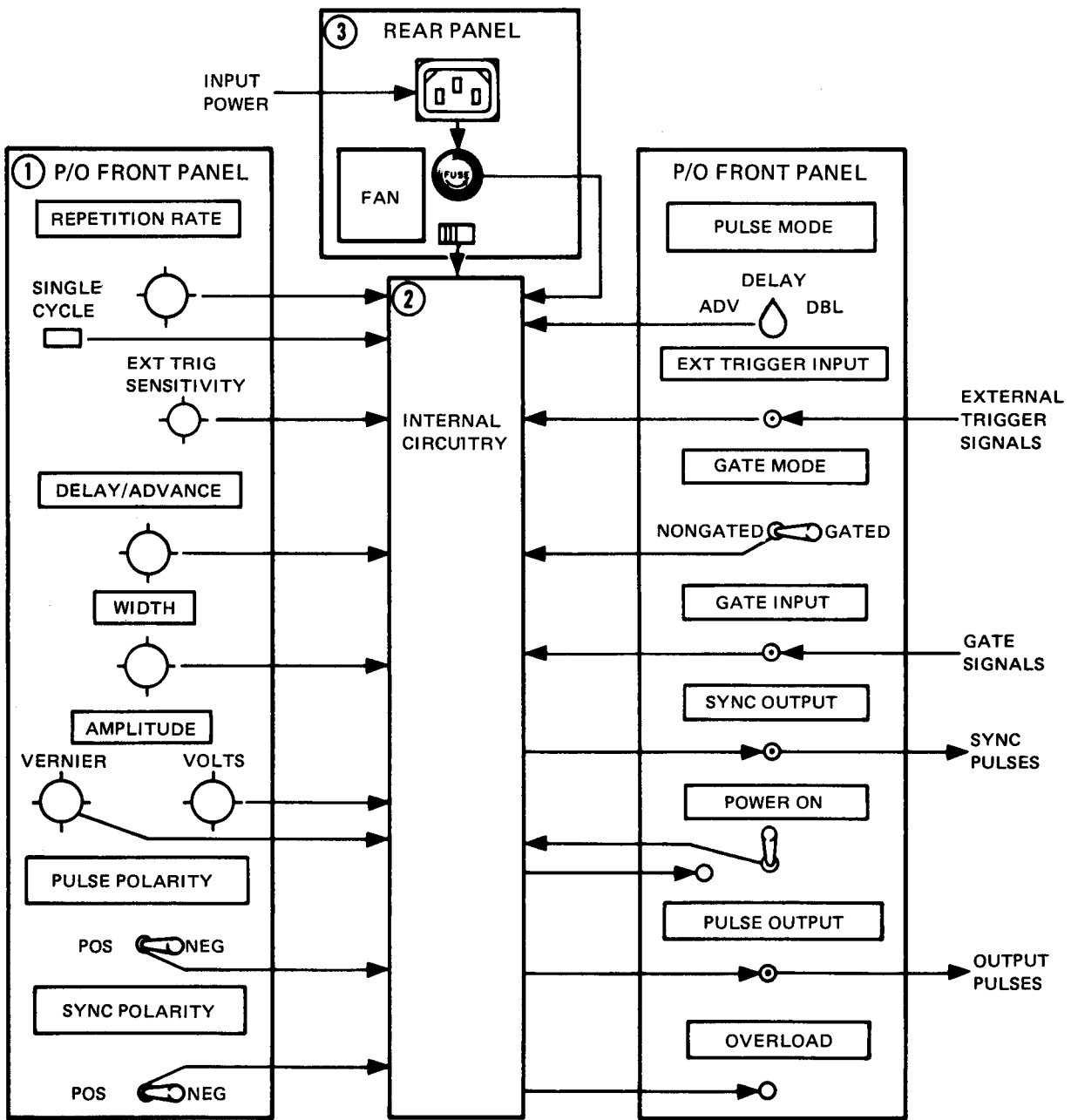

EL8ZT005

Figure 1-2. Pulse Signal Generator SG-1205(V)1/U Block Diagram

CHAPTER 2

OPERATING INSTRUCTIONS

	Para	Page
Controls and Indicators	2-2	2-1
Initial Adjustments and Daily Checks	2-5	2-11
Operating Procedures (Usual Conditions)	2-6	2-12
Operation in Dusty or Sandy Areas	2-8	2-17
Operation in Extreme Heat	2-7	2-17
Operation in Rainy or Humid Conditions	2-9	2-17
PMCS Procedures	2-4	2-5
Preventive Maintenance Table		2-9

Section 1. DESCRIPTION AND USE OF OPERATOR'S CONTROLS AND INDICATORS

2-1. GENERAL.

Before trying to operate the equipment, be sure you know where all controls and indicators are located, what each does, and what information each indicator is giving.

2-2. CONTROLS AND INDICATORS.

Operator's controls and indicators of the signal generator are shown in figure 2-1 and described in table 2-1.

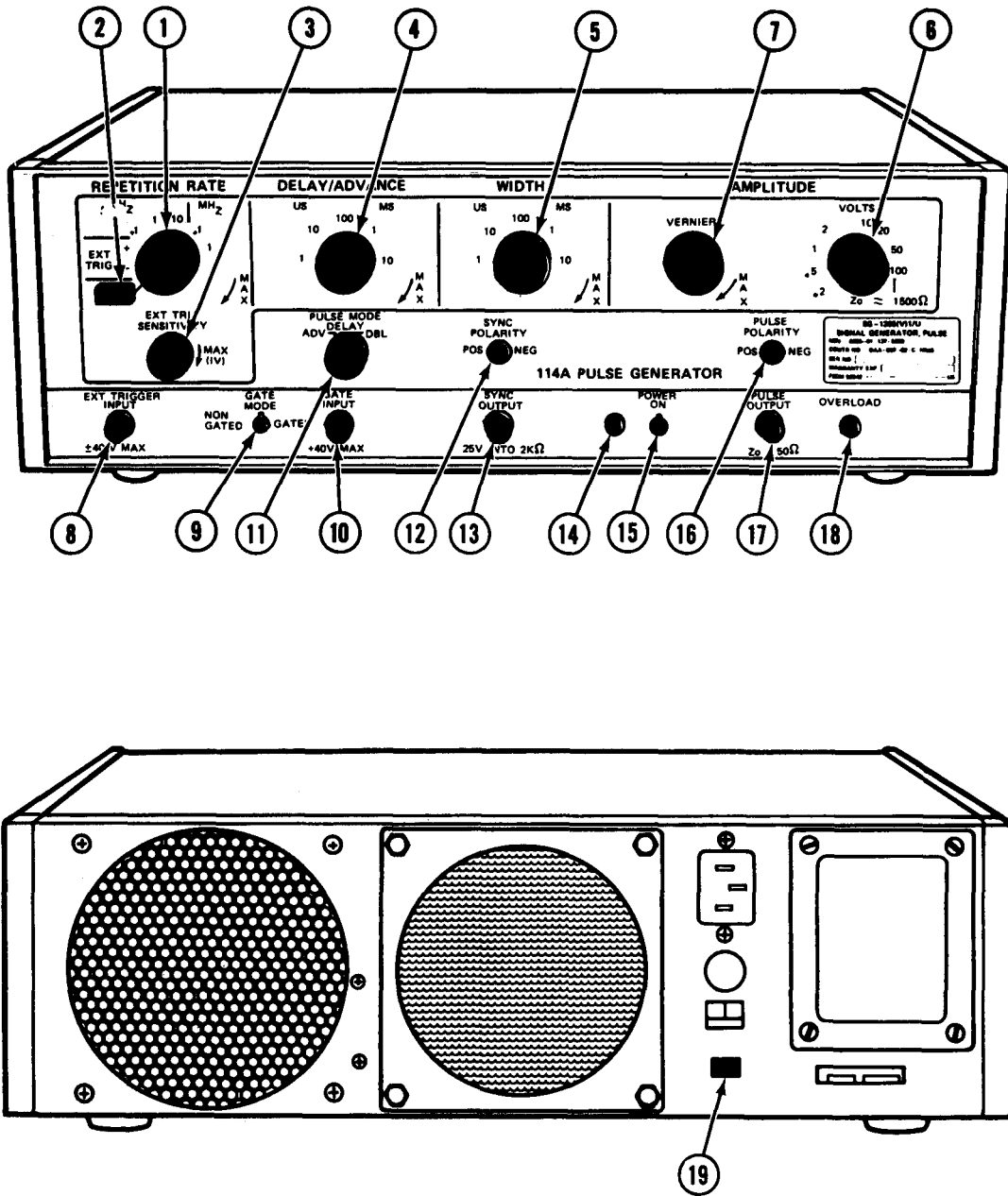

EL82T006

Figure 2-1. Operator's Controls and Indicators

Table 2-1. OPERATOR'S CONTROLS AND INDICATORS

Key	Control or Indicator	Function
1	REPETITION RATE selector switch and vernier control	Selects one of five repetition rate ranges or either (+) or (-) external trigger or single cycle modes of operation. Vernier control provides continuously variable control of repetition rate range selected.
	KHz .1 1 10	
	MHz .1 1	
	EXT TRIG + -	
	SINGLE CYCLE	
2	SINGLE CYCLE pushbutton switch	
3	EXT TRIG SENSITIVITY control potentiometer	Adjusts trigger level of external applied trigger pulse from ± 0.5 to about ± 6 V. Safe up to ± 40 V.
4	DELAY/ADVANCE selector switch and vernier control	Selects DELAY or ADVANCE range in five steps from 0 to 10 ms. Vernier control provides continuously variable control of range selected.
	US 1 10 100	
	MS 1 10	
5	WIDTH selector switch and vernier control	
	US 1 10 100	
	MS 1 10	

Table 2-1. OPERATOR'S CONTROLS AND INDICATORS - Continued

Key	Control or Indicator	Function
6	AMPLITUDE VOLTS selector switch .2 .5 1 2 5 10 20 50 100	Selects amplitude of output pulse in nine ranges from 80 mV to 100-V into 50 ohms.
7	AMPLITUDE VERNIER control	Provides continuously variable control of amplitude range selected.
8	EXT TRIGGER INPUT ± 40 V MAX connector	BNC connector for input of an external trigger.
9	GATE MODE toggle switch NON GATED GATED	Selects gating mode when placed in GATED position. When placed in NON GATED position, disables gating operation.
10	GATE INPUT +40 V MAX connector	BNC connector for input of a gating signal. Amplitude 8 V to 40 v.
11	PULSE MODE selector switch ADV DELAY DBL	Selects pulse mode of operation. ADV position allows output pulse to occur ahead of sync pulse by a period set by DELAY/ADVANCE controls. DELAY position allows output pulse to occur after sync pulse by a period of time set by DELAY/ADVANCE controls. When placed in DBL position, a pulse pair is generated for each repetition rate period. Separation of the pulse pair is determined by setting the DELAY/ADVANCE controls.
12	SYNC POLARITY toggle switch POS NEG	Selects polarity of sync pulse output.
13	SYNC OUTPUT 25 V INTO 2 $\kappa\Omega$ connector	BNC connector provides sync pulse output.
14	Power indicator	Lights when ac power is applied.

Table 2-1. OPERATOR'S CONTROLS AND INDICATORS - Continued

Key	Control or Indicator	Function
15	POWER toggle switch ON	Applies ac power to the transformer primary and blower motor.
16	PULSE POLARITY toggle switch POS NEG	Selects polarity of main pulse output.
17	PULSE OUTPUT Z.=50 Ω connector	BNC connector provides main pulse output.
18	OVERLOAD indicator	.Lights when duty cycle exceeds 50% for amplitudes <20 V and 10% for amplitudes from 20 V to 100 V.
19	Line power selector	Selects power transformer primary configuration for either 115 or 230 V.

Section II. OPERATOR PREVENTIVE MAINTENANCE CHECKS AND SERVICES (PMCS)

2-3. GENERAL.

Operator's Preventive Maintenance Checks and Services (PMCS) is the required daily and weekly inspection and care of your equipment necessary to keep it in good operating condition.

2-4. PMCS PROCEDURES.

a. *Tools, Materials, and Equipment Required for Preventive Maintenance.* No tools or equipment are required for operator preventive maintenance. The following cleaning materials will be useful to the operator:

- Lint-free cloths.
- Dishwashing compound or detergent.

b. Routine Checks and Services. Routine checks and services are not listed in the PMCS table. They are things that you should do anytime you see they must be done. If you find a routine check or service in your PMCS table, it was listed because other operators reported problems with this item. Do the following routine checks and services as necessary:

- Clean
- Dust
- Check for cut or frayed cables
- Check for dented, bent, or broken components
- Check for rusting
- Check controls for smooth operation
- Cover unused receptacles
- Check for loose nuts, bolts, and connectors
- Check for completeness of equipment
- Check for completeness and current changes to publications

c. Preventive Maintenance Checks and Services. (See table 2-2.)

- (1) Do your Before (B) preventive maintenance just before you operate your equipment. Pay attention to the CAUTIONS and WARNINGS.
- (2) Do your During (D) preventive maintenance while the equipment is in operation.
- (3) Do your After (A) preventive maintenance right after operating the equipment. Pay attention to the CAUTIONS and WARNINGS.
- (4) If something doesn't work, troubleshoot it with the instructions in this manual and notify your supervisor.
- (5) Always do your preventive maintenance in the same order until it gets to be a habit. Once you've had some practice, you'll spot anything wrong in a hurry.
- (6) If anything looks wrong and you can't fix it, write it on your DA Form 2404. If you find something seriously wrong, report it to organizational maintenance RIGHT NOW.

d. Explanation of Columns. Following is an explanation of the columns of table 2-2.

(1) *Item no.* This column contains a number for each procedure to be performed. When reporting malfunctions or failures on DA Form 2404, Equipment Inspection and Maintenance Worksheet (figure 2-2), place this number in the TM Item No. column.

EQUIPMENT INSPECTION AND MAINTENANCE WORKSHEET For use of this form, see DA PAM 738-750 and 738-751; the proponent agency is DCSLOG																																																																																																																							
1. ORGANIZATION					2. NOMENCLATURE AND MODEL																																																																																																																		
3. REGISTRATION/SERIAL/NSN		4a. MILES	b. HOURS	c. ROUNDS FIRED	d. HOT STARTS	5. DATE		6. TYPE INSPECTION																																																																																																															
7. APPLICABLE REFERENCE																																																																																																																							
TM NUMBER			TM DATE		TM NUMBER			TM DATE																																																																																																															
COLUMN a - Enter TM item number. COLUMN b - Enter the applicable condition status symbol. COLUMN c - Enter deficiencies and shortcomings.					COLUMN d - Show corrective action for deficiency or shortcoming listed in Column c. COLUMN e - Individual ascertaining completed corrective action initial in this column.																																																																																																																		
STATUS SYMBOLS																																																																																																																							
"X" - Indicates a deficiency in the equipment that places it in an inoperable status. CIRCLED "X" - Indicates a deficiency, however, the equipment may be operated under specific limitations as directed by higher authority or as prescribed locally, until corrective action can be accomplished. HORIZONTAL DASH "-" - Indicates that a required inspection, component replacement, maintenance operation check, or test flight is due but has not been accomplished, or an overdue MWO has not been accomplished.					DIAGONAL "/" - Indicates a material defect other than a deficiency which must be corrected to increase efficiency or to make the item completely serviceable. LAST NAME INITIAL IN BLACK, BLUE-BLACK INK, OR PENCIL - Indicates that a completely satisfactory condition exists. FOR AIRCRAFT - Status symbols will be recorded in red.																																																																																																																		
<i>ALL INSPECTIONS AND EQUIPMENT CONDITIONS RECORDED ON THIS FORM HAVE BEEN DETERMINED IN ACCORDANCE WITH DIAGNOSTIC PROCEDURES AND STANDARDS IN THE TM CITED HEREON.</i>																																																																																																																							
8a. SIGNATURE (Person(s) performing inspection)			8b. TIME		9a. SIGNATURE (Maintenance Supervisor)			9b. TIME	10. MANHOURS REQUIRED																																																																																																														
<table border="1" style="width:100%; border-collapse: collapse;"> <thead> <tr> <th style="width: 5%;">TM ITEM NO. <i>a</i></th> <th style="width: 5%;">STATUS <i>b</i></th> <th style="width: 35%;">DEFICIENCIES AND SHORTCOMINGS <i>c</i></th> <th style="width: 35%;">CORRECTIVE ACTION <i>d</i></th> <th style="width: 10%;">INITIAL WHEN CORRECTED <i>e</i></th> </tr> </thead> <tbody> <tr><td> </td><td> </td><td> </td><td> </td><td> </td></tr> <tr><td> </td><td> </td><td> </td><td> </td><td> </td></tr> <tr><td> </td><td> </td><td> </td><td> </td><td> </td></tr> <tr><td> </td><td> </td><td> </td><td> </td><td> </td></tr> <tr><td> </td><td> </td><td> </td><td> </td><td> </td></tr> <tr><td> </td><td> </td><td> </td><td> </td><td> </td></tr> <tr><td> </td><td> </td><td> </td><td> </td><td> </td></tr> <tr><td> </td><td> </td><td> </td><td> </td><td> </td></tr> <tr><td> </td><td> </td><td> </td><td> </td><td> </td></tr> <tr><td> </td><td> </td><td> </td><td> </td><td> </td></tr> <tr><td> </td><td> </td><td> </td><td> </td><td> </td></tr> <tr><td> </td><td> </td><td> </td><td> </td><td> </td></tr> <tr><td> </td><td> </td><td> </td><td> </td><td> </td></tr> <tr><td> </td><td> </td><td> </td><td> </td><td> </td></tr> <tr><td> </td><td> </td><td> </td><td> </td><td> </td></tr> <tr><td> </td><td> </td><td> </td><td> </td><td> </td></tr> <tr><td> </td><td> </td><td> </td><td> </td><td> </td></tr> <tr><td> </td><td> </td><td> </td><td> </td><td> </td></tr> <tr><td> </td><td> </td><td> </td><td> </td><td> </td></tr> <tr><td> </td><td> </td><td> </td><td> </td><td> </td></tr> <tr><td> </td><td> </td><td> </td><td> </td><td> </td></tr> </tbody> </table>										TM ITEM NO. <i>a</i>	STATUS <i>b</i>	DEFICIENCIES AND SHORTCOMINGS <i>c</i>	CORRECTIVE ACTION <i>d</i>	INITIAL WHEN CORRECTED <i>e</i>																																																																																																									
TM ITEM NO. <i>a</i>	STATUS <i>b</i>	DEFICIENCIES AND SHORTCOMINGS <i>c</i>	CORRECTIVE ACTION <i>d</i>	INITIAL WHEN CORRECTED <i>e</i>																																																																																																																			



DA FORM 2404, APR 79

Replaces edition of 1 Jan 64, which will be used

USAPPC V1.10

Figure 2-2. DA Form 2404

(2) *Interval.* These columns tell you when to do a procedure. Each column that applies will contain a dot (•). Some procedures will have dots in more than one column.

NOTE

All PMCS must be done as regularly scheduled and also under the following conditions:

- Before the equipment is used on a mission
- When the equipment is first installed
- When the equipment is reinstalled after being removed for any reason.

(3) *Item to be inspected/procedure.* This column contains the name of the item to be inspected and tells how to perform the required checks and services on it. Carefully follow these instructions and perform them in the order listed.

(4) *Equipment is not ready/available if:* This column tells you:

- Why your equipment cannot be used
- Why there is a problem with any item that was inspected
- What the problem is with the procedure.

Table 2-2. OPERATOR PREVENTIVE MAINTENANCE CHECKS AND SERVICES - Continued

NOTE

If the equipment must be kept in continuous operation, check and service only those items that can be checked and serviced without disturbing operation. Make the complete checks and services when the equipment can be shut down.

These checks are to be made in the order listed, within the designated interval.

B-Before operation D-During operation A-After operation

Item No.	Interval			Item to be Inspected Procedure	Equipment is Not Ready/ Available if:
	B	D	A		
1				Front Panel Controls	
	•			a. Check that knobs are not cracked or broken.	Knobs are broken or missing.
	•			b. Check that switches are not loose.	
2				Front Panel Connectors	
	•			a. Check that connectors are not tarnished or dirty.	
	•			b. Check that connectors are not bent or loose.	Connectors are broken or cannot be used.
3				Front Panel	
	•			a. Check that front panel markings are complete and readable.	
		•		b. Check that power indicator is lit when POWER switch is set to ON.	
		•	c. Check that OVERLOAD indicator does not flash or remain lit after POWER switch is set to ON.	OVERLOAD indicator flashes or remains lit.	

Table 2-2. OPERATOR PREVENTIVE MAINTENANCE CHECKS AND SERVICES - Continued

Item No.	Interval			Item to be Inspected Procedure	Equipment is Not Ready/ Available if:
	B	D	A		
4	•			a. Check that top and bottom covers are secure and in place.	Top or bottom cover is not in place.
	•			b. Check that handles are secure and are not broken.	
	•			c. Check that chassis feet are not missing or broken.	
	•		•	d. Check chassis for dents, deep scratches, and chipped paint.	
5	•			Power Cable Check that power cable is not frayed or cut.	Power cable is damaged.
6	•			a. Check that line power selector switch is set for correct input voltage.	Switch is not set for correct input voltage.
		•		b. Check that air is being drawn into chassis through air filter when POWER switch is set to ON.	Air is not being drawn into chassis.
	•			c. Check that air filter is clean.	

Section III. OPERATION UNDER USUAL

2-5. INITIAL ADJUSTMENTS AND DAILY CHECKS.

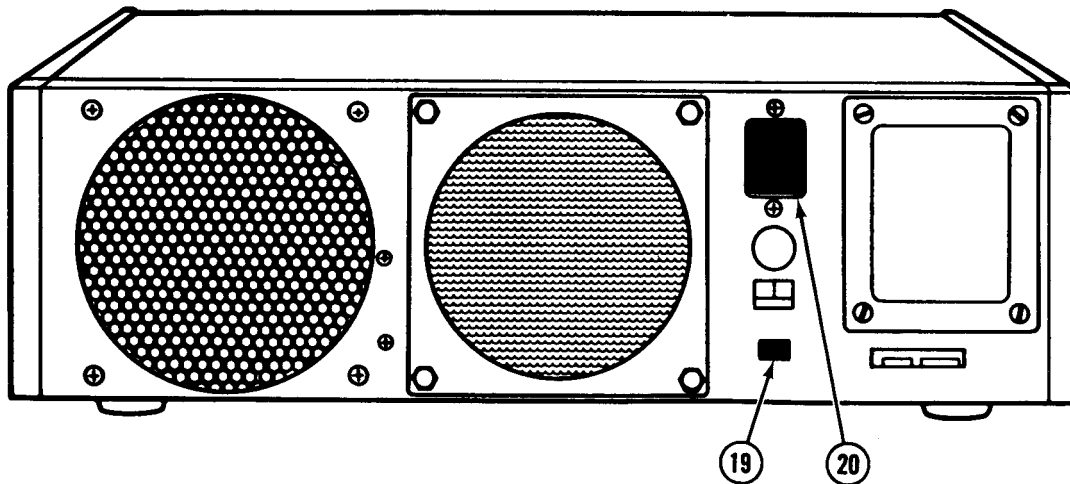
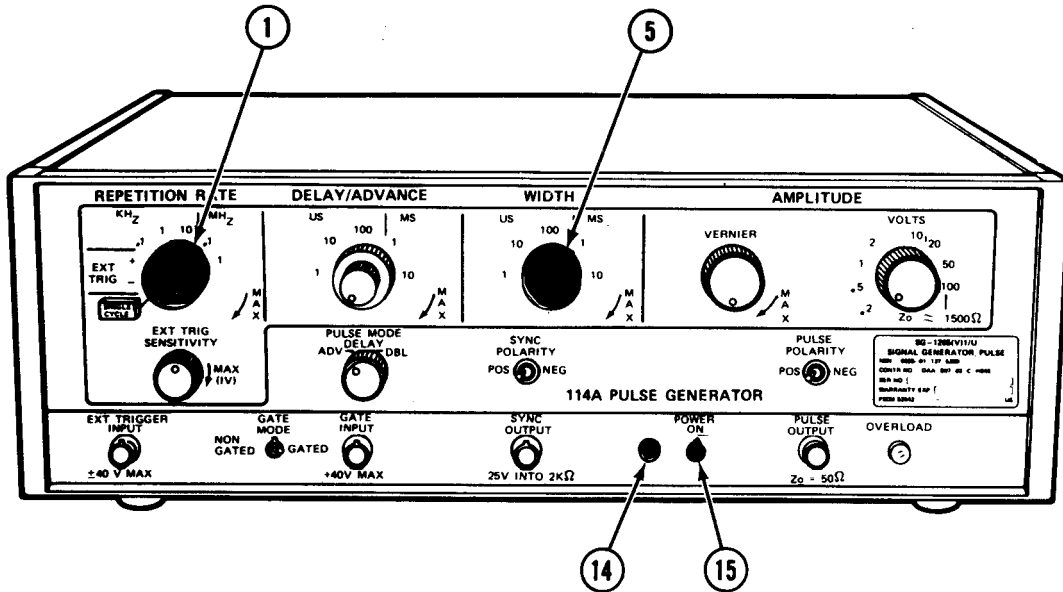

EL8ZT008

- a. Check local power source and set rear panel line power selector switch (19) to either 115 V or 230 V. If using other than 115 V, obtain correct adapter for power cord.
- b. Set REPETITION RATE switch (1) and pulse WIDTH switch (5) to minimum to avoid overloading signal generator.

- c. Connect power cord to ac power cord receptacle (20) and local power source.
- d. Set POWER switch (15) to ON.
- e. Check that power indicator (14) lights and listen to make sure fan is running.

2-6. OPERATING PROCEDURES.

a. *Output Connections.*

(1) *Output termination.* To ensure clean waveforms with fast transition times and minimum distortion when the signal generator is connected to loads several feet away -

- Use 50-ohm coaxial cabling
- Use nonreactive 50-ohm terminations connected at the load rather than at the signal generator.

(2) *Multiple pulse output.* Several signal generators may be connected together to simulate a multiple-signal generator. All pulses are selectable in polarity with pulse parameters controlled individually. The group may be driven in parallel (from an external source) or in tandem (using the sync output of one signal generator to externally drive the next) as shown in figure 2-3. Pulse repetition rates well above 1 MHz can be obtained by this method. Good waveform fidelity is obtained by using the amplitude controls to attenuate each pulse so that the signal generator attenuators terminate the interconnecting cables with 50 ohms impedance and reduce pulse distorting reflections.

b. *Basic Operation.* Basic operation is the operation of the signal generator to produce output pulses using only the signal generator internal circuitry. Four other options are provided:

- Sync output
- External triggering
- Manual triggering
- Gated output.

If any of these options are desired, follow the procedures in basic operation and adjust them as described for the option selected.

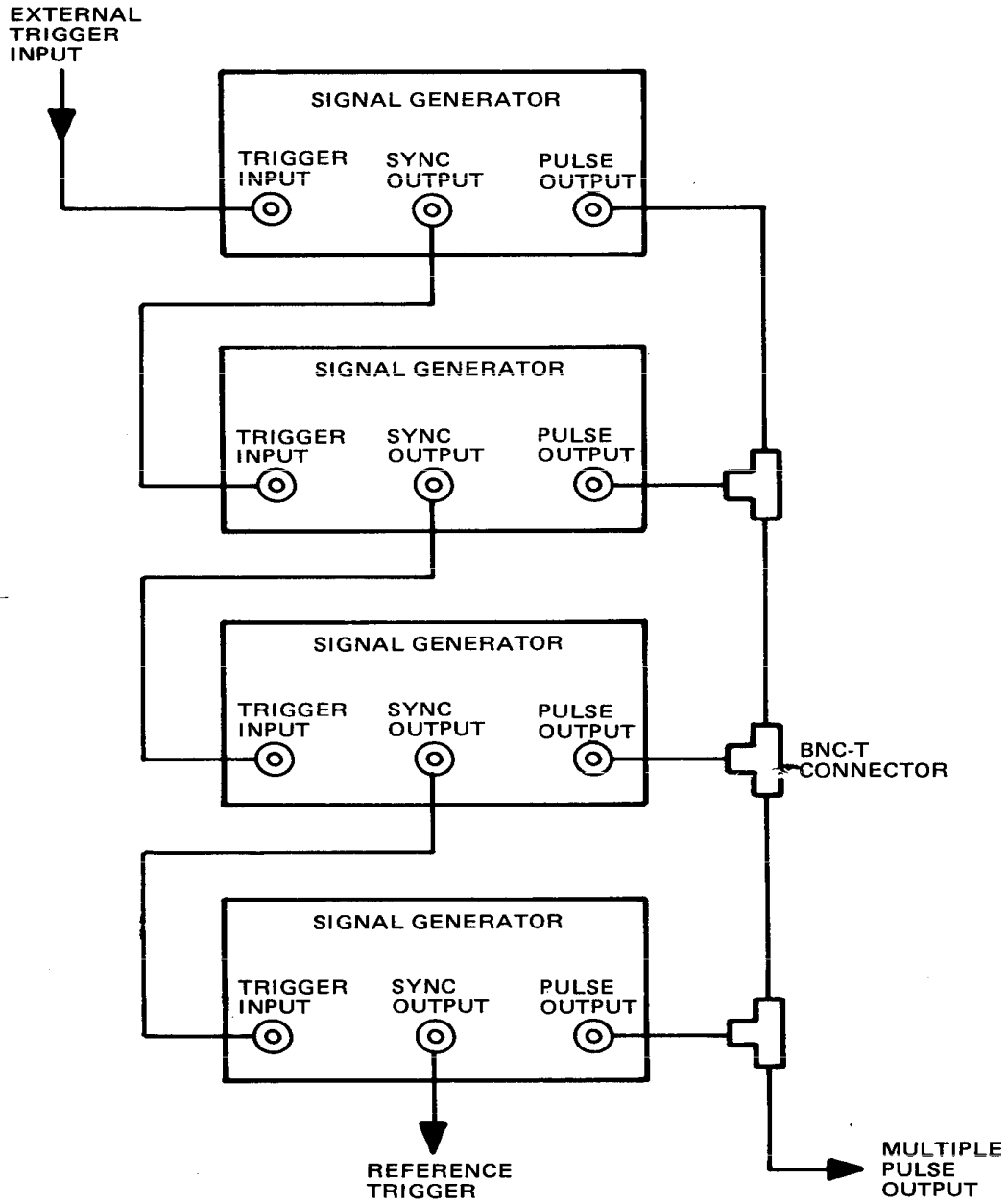

- NOTE:**
1. - ALL CABLES ARE 50 OHM COAXIAL CABLES WITH BNC CONNECTORS.
 2. -CONNECT BNC-T CONNECTORS DIRECTLY TO OUTPUT JACKS AND MAKE INTERCONNECTING CABLES AS SHORT AS POSSIBLE.

EL8ZT009

Figure 2-3. Multiple Pulse Output Connections

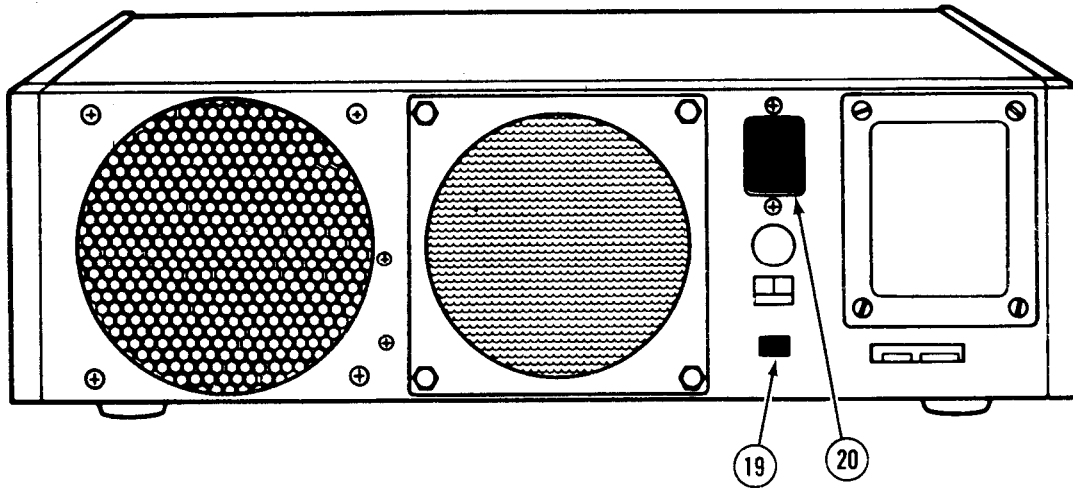
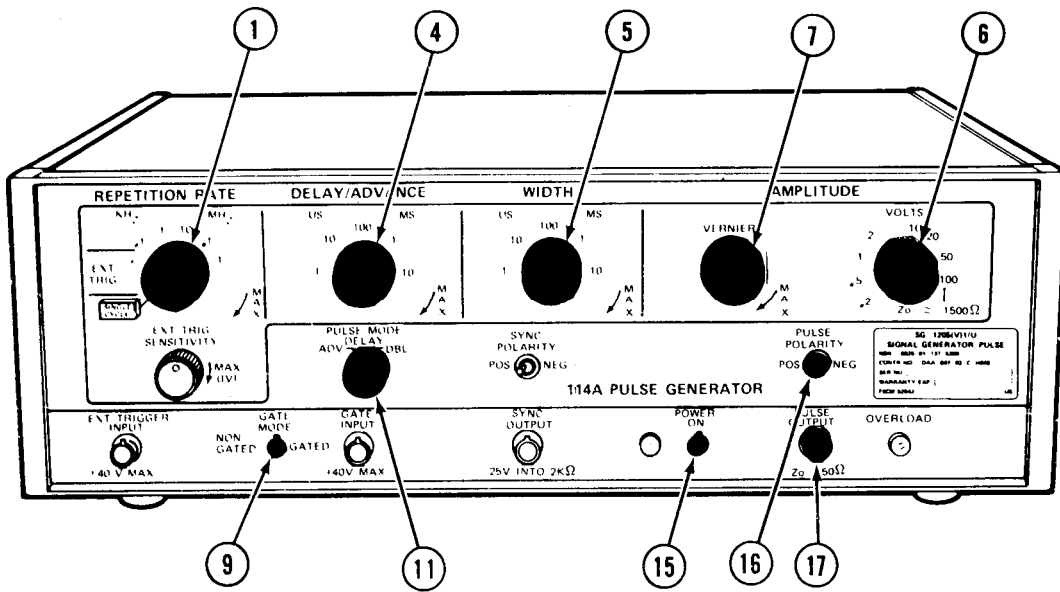

EL8ZT010

WARNING

Line power selector switch (19) must match input line voltage or equipment will be damaged.

- (1) Connect power cord to ac power cord receptacle (20) and local power source.

- (2) Connect cable with BNC connector to PULSE OUTPUT connector (17) and load.
- (3) Set PULSE MODE control (11) to:
 - ADV - to allow output pulse to occur ahead of sync pulse
 - DELAY - to allow output pulse to occur after sync pulse
 - DBL - to receive a pulse pair during each repetition rate period.
- (4) Set DELAY/ADVANCE control (4) to one of five ranges to select separation time of the output and sync pulses or the pulse pair. Adjust vernier control for continuously variable control of the range selected.
- (5) Set AMPLITUDE VOLTS control (6) to desired pulse amplitude range. Adjust AMPLITUDE VERNIER control (7) for continuously variable control of the range.

WARNING

Maximum duty factor (cycle) is 50 percent for amplitudes of up to 20 V and 10 percent for amplitudes from 20 to 100 V. Always decrease the repetition rate before increasing the pulse width and decrease the pulse width before increasing the repetition rate to prevent overload.

- (6) Set REPETITION RATE control (1) to one of five ranges to select repetition rate period. Adjust vernier control for continuously variable control of the range selected.
- (7) Set WIDTH control (5) to desired pulse width range. Adjust vernier control for continuously variable control of range.
- (8) Set PULSE POLARITY switch (16) for a positive (POS) or negative (NEG) output pulse as desired.
- (9) Set GATE MODE switch (9) to NON GATED.
- (10) Set POWER switch (15) to ON and let signal generator warm up for about 20 minutes.
- (11) When operation is complete, set POWER switch (15) to off and disconnect all cables.

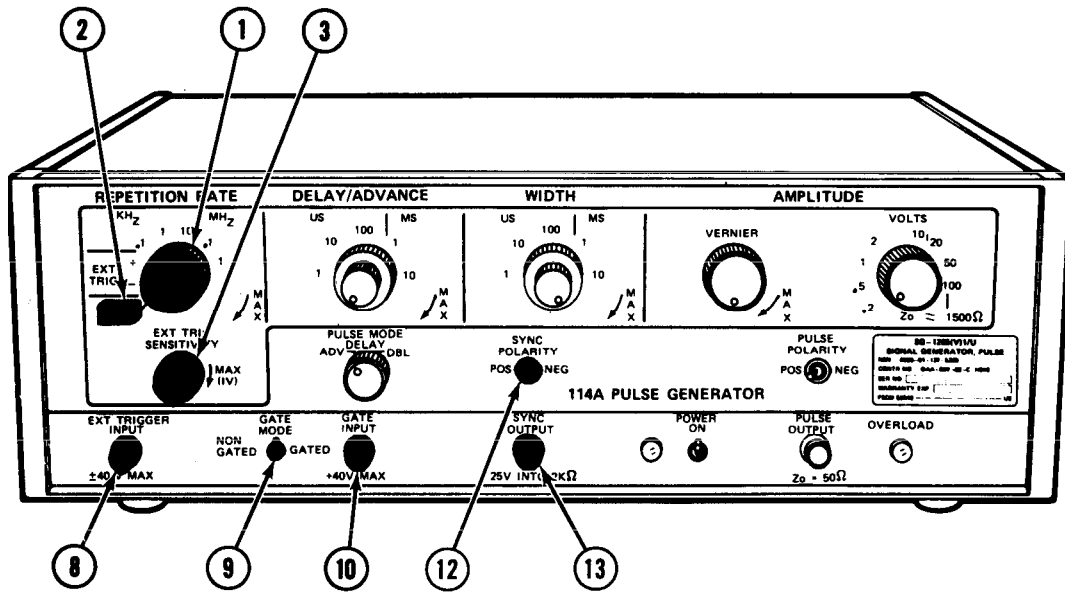

EL82T011

c. *Sync Output.* A sync output pulse is provided to synchronize another piece of equipment with the signal generator.

- (1) Connect cable with BNC connector to SYNC OUTPUT connector (13) and load.
- (2) Set SYNC POLARITY switch (12) for a positive (POS) or negative (NEG) sync pulse as desired.

d. *External Triggering.* The signal generator's internal trigger circuit can be bypassed to trigger the signal generator from an external source.

- (1) Connect cable with a BNC connector to EXT TRIGGER INPUT connector (8) and external trigger source.
- (2) Set REPETITION RATE control (1) to EXT TRIG + for positive triggering or - for negative triggering.
- (3) Adjust EXT TRIG SENSITIVITY control (3) for desired input trigger level.

e. *Manual Triggering.* The signal generator's internal trigger circuit can be bypassed to trigger the signal generator manually.

- (1) Set REPETITION RATE control (1) to SINGLE CYCLE.
- (2) Press SINGLE CYCLE pushbutton (2) each time a trigger pulse is desired.

f. *Gated Output.* An external gate signal may be applied to gate the output pulse.

- (1) Connect cable with BNC connector to GATE INPUT connector (10) and gating signal source.
- (2) Set GATE MODE switch (9) to GATED.

Section IV. OPERATION UNDER UNUSUAL CONDITIONS

2-7. OPERATION IN EXTREME HEAT.

- a. Protect signal generator from direct sunlight.
- b. Do not obstruct air flow around signal generator, especially around the rear intake and exhaust vents.
- c. Check air filter frequently for dirt and other obstructions that would reduce air intake.

2-8. OPERATION IN DUSTY OR SANDY AREAS.

- a. Keep signal generator as clean as possible.

CAUTION

Never operate the signal generator without having the air filter in place.

- b. Check air filter frequently for dirt and dust that would reduce air intake.
- c. Cover signal generator when not in use.

2-9. OPERATION IN RAINY OR HUMID CONDITIONS.

- a. Take special precautions to keep signal generator dry.
- b. Check connectors and chassis frequently for rust and corrosion.

**CHAPTER 3
ORGANIZATIONAL MAINTENANCE INSTRUCTIONS**

	Para	Page
Common Tools and Equipment	3-1	3-1
Operational Test.....	3-11	3-8
PMCS Procedures	3-7	3-3
Preliminary Servicing and Adjustment of Equipment.....	3-5	3-2
Preparation for Storage or Shipment	3-15	3-13
Repair Parts	3-3	3-1
Replace Air Filter.....	3-14	3-12
Replace Front Panel Control Knobs	3-13	3-10
Replace Fuse	3-12	3-9
Service Upon Receipt of Material	3-4	3-2
Special Tools, TMDE, and Support Equipment	3-2	3-1
Symptom Index		3-5
Troubleshooting Table	3-10	3-6
Types of Storage	3-16	3-13
Using the Troubleshooting Table	3-9	3-6

**Section I. REPAIR PARTS SPECIAL TOOLS; TEST, MEASUREMENT, AND DIAGNOSTIC
EQUIPMENT (TMDE); AND SUPPORT EQUIPMENT**

3-1. COMMON TOOLS AND EQUIPMENT.

Common tools and equipment required for organizational maintenance of Pulse Signal Generator SG-1205(V)1/U are listed in Appendix B (Maintenance Allocation Chart).

3-2. SPECIAL TOOLS, TMDE, AND SUPPORT EQUIPMENT.

There are no special tools required for organizational maintenance of the signal generator.

3-3. REPAIR PARTS.

Repair parts are listed and illustrated in the repair parts and special tools list, TM 11-6625-3050-24P, covering organizational and general support maintenance for this equipment.

Section II. SERVICE UPON RECEIPT

3-4. SERVICE UPON RECEIPT OF MATERIAL.

a. *Unpacking.* The signal generator is packed in its own shipping carton. Unpack the equipment as follows:

- (1) Open shipping carton and remove equipment.
- (2) Place equipment on a suitable clean and dry surface for inspection.
- (3) Keep all shipping materials for use in repacking and reshipping.

b. *Checking Unpacked Equipment.*

- (1) Inspect the equipment for damage incurred during shipment. If the equipment has been damaged, report the damage on SF-364, Report of Discrepancy (ROD).
- (2) Check the equipment against the packing slip to see if the shipment is complete. Report all discrepancies in accordance with the instructions in TM 750-8.
- (3) Check to see whether the equipment has been modified.

3-5. PRELIMINARY SERVICING AND ADJUSTMENT OF EQUIPMENT.

- a. Remove fuse. See paragraph 3-12. Check that fuse is correct for input line voltage being used. Install fuse. See paragraph 3-12.
- b. Set rear panel line power selector switch for input line voltage being used. If input line voltage being used is not 115 or 230 V ac, have general support maintenance reconfigure power transformer.
- c. Perform operational test. See paragraph 3-11.

Section III. PREVENTIVE MAINTENANCE CHECKS AND SERVICES (PMCS)

3-6. GENERAL.

Preventive Maintenance Checks and Services (PMCS) are done to find and to fix problems before they can cause major damage to the equipment. These checks and services are done by organizational maintenance personnel at monthly intervals according to the PMCS table. To save time and make sure that all items are checked, do the PMCS in the order given in the table. Write down any problems on the proper forms. Refer to TM 750-8.

3-7. PMCS PROCEDURES.

a. Table 3-1 gives PMCS procedures for the signal generator. The PMCS table is made up of the following columns:

(1) *Item no.* This column gives the order in which the checks and services are to be done. Use these item numbers when filling out the TM Item No. Column on DA Form 2404, Equipment Inspection and Maintenance Worksheet.

(2) *Item to be inspected.* This column names the item to be checked or serviced.

(3) *Procedures.* This column gives the checks and services that need to be done on the item.

b. The PMCS procedures do not say “adjust if necessary” or “replace if necessary.” It is understood that whenever inspection shows the need for adjustment, repairs, or replacement, that work will be done.

Table 3-1. ORGANIZATIONAL PREVENTIVE MAINTENANCE CHECKS AND SERVICES MONTHLY SCHEDULE

NOTE

If the equipment must be kept in continuous operation, check and service only those items that can be checked and serviced without disturbing operation. Make the complete checks and services when the equipment can be shut down.

These checks are to be made in the order listed, at monthly intervals.

Item No.	Item To be Inspected	Procedures
1	Air Filter	<p style="text-align: center;">WARNING</p> <p style="text-align: center;">Use isopropyl alcohol in a well ventilated area. Do not breathe fumes for a long period of time.</p> <p style="text-align: center;">CAUTION</p> <ul style="list-style-type: none"> • If signal generator is used in sand or dusty areas or for extended periods of time, air filter may need cleaning more often to prevent damage to equipment. • Use care when installing air filter. Filter housing can be damaged if capnuts are tightened too tight. <p>Remove air filter by removing four capnuts and filter housing. Clean air filter with compressed air or isopropyl alcohol. Install air filter, filter housing, and four capnuts.</p>

Section IV. TROUBLESHOOTING

SYMPTOM INDEX

Signal Generator Symptom	Page
1. NO PULSE OUTPUT	3-7
2. OVERLOAD INDICATOR IS LIT.....	3-7

3-8. GENERAL.

Troubleshooting at the organizational maintenance level requires you to locate any trouble as quickly as possible. The amount of troubleshooting you can do is based on what the Maintenance Allocation Chart says you can fix. Because of this, the only trouble symptoms you will find here are those that could be caused by faulty items you can fix.

NOTE

Before using the troubleshooting table, check your work order and talk to the operator, if possible, for a description of symptoms if trouble occurred while equipment was in operation.



3-9. USING THE TROUBLESHOOTING TABLE.

TM 11-6625-3050-12	
Table 3-2. TROUBLESHOOTING	
Malfunction	Test or Inspection Corrective Action
<p>① → 1. NO PULSE OUTPUT.</p> <p>② →</p> <p>③ →</p>	<p>Step 1. Check that power indicator is lit.</p> <ul style="list-style-type: none"> • If indicator is not lit, go to step 2. • If indicator is lit, go to step 4. <p>Step 2. Check that POWER switch is in ON position.</p> <ul style="list-style-type: none"> • Set switch to ON.

EL8ZT012

- ① Malfunctions are those that cause symptoms seen or heard at the equipment without using test equipment.
- ② Tests or Inspections are procedure steps that isolate the damaged part.
- ③ Corrective action tells technician what needs to be done to correct the problems.

3-10. TROUBLESHOOTING TABLE.

Table 3-2 lists common malfunctions which may be found during operation or maintenance of the signal generator. You should perform the tests/inspections and corrective actions in the order listed.

NOTE

This manual cannot list all malfunctions that may occur, nor all tests or inspections and corrective actions. If a malfunction is not listed or is not corrected by listed corrective actions, notify next higher level of maintenance.

Table 3-2. TROUBLESHOOTING

Malfunction	Test or Inspection	Corrective Action
1. NO PULSE OUTPUT.	Step 1. Check that power indicator is lit.	<ul style="list-style-type: none"> Ž If indicator is not lit, go to step 2. Ž If indicator is lit, go to step 4.
	Step 2. Check that POWER switch is in ON position.	Ž Set switch to ON.
	Step 3. Check that fan is drawing air into signal generator.	<p>Hold hand across filter in center of back panel.</p> <ul style="list-style-type: none"> Ž If air is felt flowing into signal generator, contact next higher level of maintenance. Ž If air is not felt flowing into signal generator, set POWER switch to off and replace fuse. See paragraph 3-12. Ž If fan does not draw air after fuse is replaced, contact next higher level of maintenance.
	Step 4. Check that REPETITION RATE switch is set to KHz or MHz position.	Ž Set switch to a KHz or MHz position.
	Step 5. Check that GATE MODE switch is set to NON GATED position.	<ul style="list-style-type: none"> Ž Set switch to NON GATED position. Ž If there is still no pulse output, contact next higher level of maintenance.
2. OVERLOAD INDICATOR IS LIT.	Check that duty factor is within limits.	If AMPLITUDE VOLTS switch is set to 20 or less, pulse width must be less than 50% of pulse repetition time.

Table 3-2. TROUBLESHOOTING - Continued

Malfunction	Test or Inspection	Corrective Action
	<p>If AMPLITUDE VOLTS switch is set to more than 20, pulse width must be less than 10% of pulse repetition time.</p> <ul style="list-style-type: none"> • Reset AMPLITUDE VOLTS or REPETITION RATE switch to get correct duty factor. • If OVERLOAD indicate is lit with correct duty factor selected, contact next higher level of maintenance. 	

Section V. MAINTENANCE PROCEDURES

3-11. OPERATIONAL TEST.

1. Plug power cord (1) into rear panel connector (2) and power source.
2. Set REPETITION RATE switch (3) to .1 KHz.
3. Set WIDTH switch (4) to 1 μ s.
4. Set POWER switch (5) to ON.
5. Check that power indicator (6) is lit.
6. Check that OVERLOAD indicator (7) is not lit.
7. Check that air is being drawn into chassis through air filter (8).
8. Set POWER switch (5) to off.
9. Unplug power cord (1).

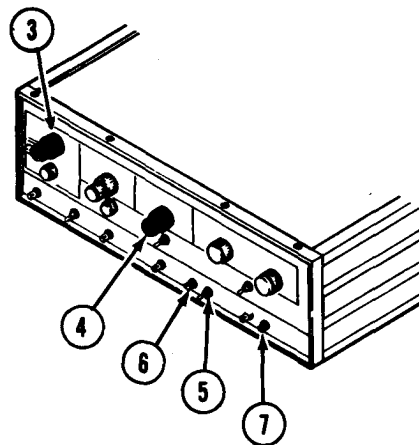
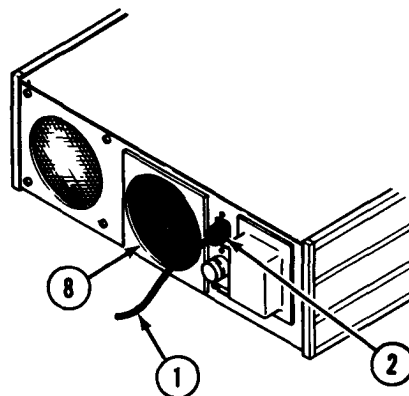

EL8ZT013

END OF TEST

3-12. REPLACE FUSE.**DESCRIPTION**

This procedure covers: Remove. install.

REMOVE

1. Working at front panel, set POWER switch (1) to off.
2. Unplug power cable (2) from power source.
3. Working at rear panel, push in and unscrew fuseholder cap (3) 1/4 turn to left.
4. Pull fuse (4) out of fuseholder cap (3).

INSTALL

1. Working at rear panel, insert fuse (4) into fuseholder cap (3).
2. Push fuseholder cap (3) into socket (5) and turn 1/4 turn to right.
3. Plug power cable (2) into power source.
4. Working at front panel, set POWER switch (1) to ON.

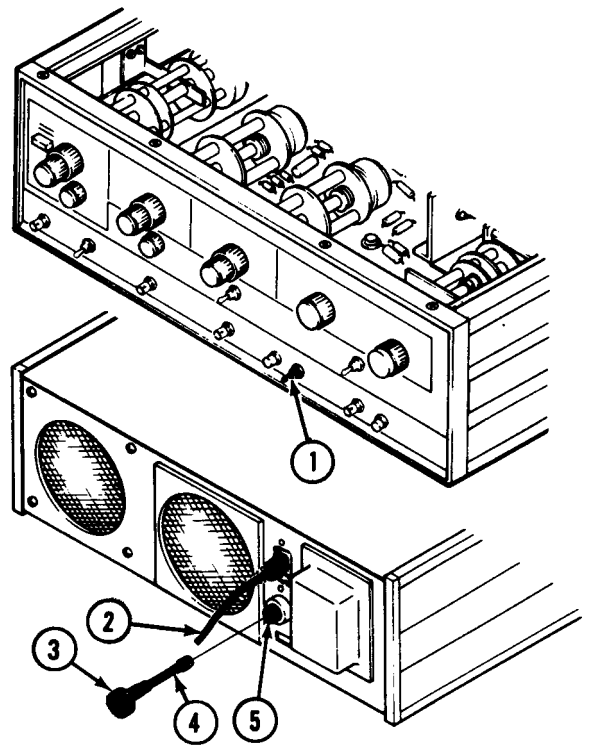

EL8ZT014

END OF TASK

3-13. REPLACE FRONT PANEL CONTROL KNOBS.

DESCRIPTION

This procedure covers: Switches With One Knob. Remove. Install.
Switches With Two Knobs. Remove. Install.

REMOVE SWITCHES WITH ONE KNOB

1. Set POWER switch (1) to off.
2. Turn knob (2) to far left position.
3. Loosen two setscrews (3).
4. Pull knob (2) off switch (4).

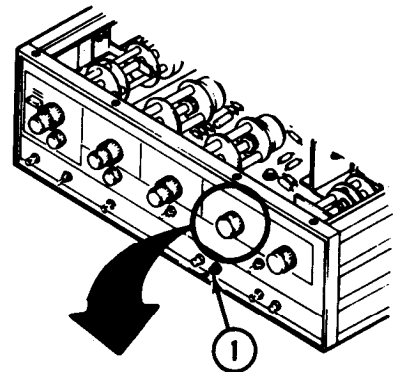

INSTALL SWITCHES WITH ONE KNOB

1. Push knob (2) onto switch (4).
2. Aline mark (5) on knob (2) with far left front panel marking.
3. Tighten two setscrews (3).
4. Rotate knob (2) and check that mark (5) on knob aligns with each front panel marking.

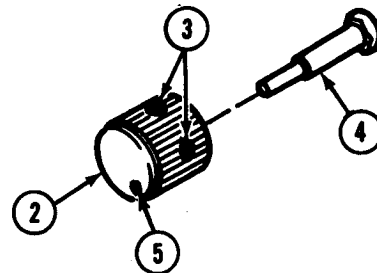

EL82T015

END OF TASK

REMOVE SWITCHES WITH TWO KNOBS

NOTE

If outer knob is to be removed, do steps 1 thru 4. If inner knob or both knobs are to be removed, do steps 1 thru 5.

1. Set POWER switch (1) to off.
2. Turn outer knob (2) and inner knob (3) to far left position.
3. Loosen two setscrews (4) in outer knob (2).
4. Pull outer knob (2) off switch (5).
5. Loosen two setscrews (6) on inner knob (3).
6. Pull inner knob (3) off switch (5).

INSTALL SWITCHES WITH TWO KNOBS

NOTE

If inner knob or both knobs are being installed, do steps 1 thru 8. If outer knob is being installed, do steps 5 thru 8.

1. Push inner knob (3) onto switch (5).
2. Aline mark (7) on inner knob (3) with far left front panel marking.
3. Tighten two setscrews (6).
4. Rotate inner knob (3) and check that mark (7) on knob alines with each front panel marking.
5. Push outer knob (2) onto switch (5).
6. Aline mark (8) on outer knob (2) with far left front panel marking.
7. Tighten two setscrews (4).
8. Rotate outer knob (2) and check that mark (8) on knob alines with front panel markings.

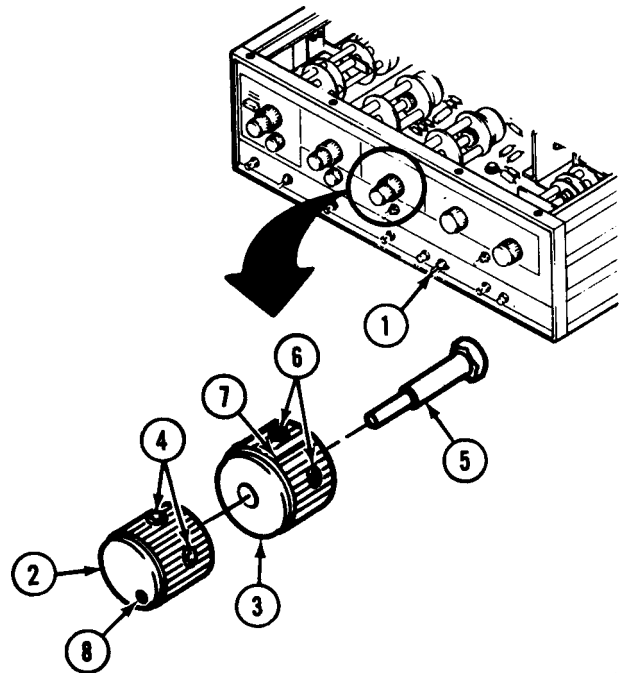

EL8ZT016

END OF TASK

3-14. REPLACE AIR FILTER.

DESCRIPTION

This procedure covers: Remove. Install.

REMOVE

1. Working at front panel, set POWER switch (1) to off.
2. Working at rear panel, remove four capnuts (2).
3. Pull off filter housing (3) and air filter (4).

INSTALL

1. Working at rear panel, position air filter (4) and filter housing (3) on four screws (5).

CAUTION

Filter housing (3) can be damaged if capnuts (2) are tightened too tight.

2. Install four capnuts (2).

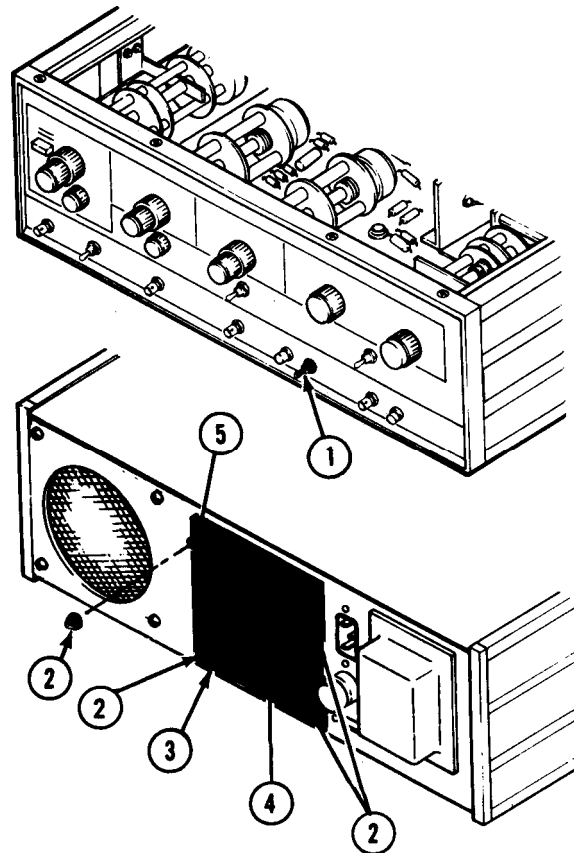

EL8ZT017

END OF TASK

Section VI. PREPARATION FOR STORAGE OR SHIPMENT**3-15. PREPARATION FOR STORAGE OR SHIPMENT.**

- a. Wrap the signal generator in heavy paper or plastic prior to placing it into the shipping container.
- b. Select a strong shipping container or wooden box to contain the signal generator.
- c. Use an adequate layer of shock-absorbing material on all sides of the signal generator (3- to 5-inch layer) to provide cushioning and prevent movement inside the container. Protect the front panel with additional layers of cardboard.
- d. Seal the package with filament tape; if a wooden box is used, strap with metal bands.
- e. Mark the shipping container "FRAGILE-DELICATE INSTRUMENT" to insure proper handling.

3-16. TYPES OF STORAGE.

- a. Short-term (administrative) = 1 to 45 days. All equipment in administrative storage must be able to be made ready within 24 hours for use on a mission. Before placing any item in administrative storage, make sure the next scheduled PMCS has been done and any deficiencies have been corrected. The administrative storage site should provide required protection from extreme weather conditions and allow you to reach the equipment for visual inspections or exercises when applicable.
- b. Intermediate = 46 to 180 days.
- c. Long-term = over 180 days.

**APPENDIX A
REFERENCES**

A-1. SCOPE.

This appendix lists all forms, field manuals, technical manuals, and miscellaneous publication references in this manual.

A-2. FORMS.

Equipment Inspection and Maintenance Worksheet DA Form 2404
 Hand Receipt..... DA Form 2062
 Product Quality Deficiency Report..... SF 368
 Recommended Changes to Publications and Blank Forms..... DA Form 2028
 Report of Discrepancy (ROD)..... SF 364

A-3. TECHNICAL MANUALS.

Organizational, Direct Support and General Support
 Maintenance Repair Parts and Special Tools List (Including
 Depot Maintenance Repair Parts and Special Tools)
 For Pulse Signal Generator, SG-1205(V)1/U
 (NSN 6625-01-137-5369) TM 11-6625-3050-24P
 Procedures for Destruction of Electronics Materiel
 to Prevent Enemy Use (Electronics Command) TM 750-244-2
 The Army Maintenance Management System (TAMMS) Users Manual TM 750-8

A-4. MISCELLANEOUS PUBLICATIONS.

The American Society of Mechanical Engineers,
 Abbreviations and Acronyms..... ASME Y14.38
 Expendable/Durable Items (Except Medical, Class V,
 Repair Parts, and Heraldic Items)..... CTA 50-970
 Consolidated Index of Army Publications and Blank Forms DA Pam 25-30
 First Aid FM 4-25.11
 Reporting of Supply Discrepancies AR 735-11-2
 Safety Requirements for Maintenance of Electrical
 and Electronic Equipment TB 385-4

APPENDIX B

MAINTENANCE ALLOCATION CHART

Section I. INTRODUCTION

B-1. GENERAL.

This appendix provides a summary of the maintenance operations for Pulse Signal Generator SG-1205(V)1/U. It authorizes categories of maintenance for specific maintenance functions on repairable items and components and the tools and equipment required to perform each function. This appendix may be used as an aid in planning maintenance operations.

B-2. MAINTENANCE FUNCTIONS.

Maintenance functions will be limited to and defined as follows:

a. Inspect. To determine the serviceability of an item by comparing its physical, mechanical, and/or electrical characteristics with established standards through examination.

b. Test. To verify serviceability and to detect incipient failure by measuring the mechanical or electrical characteristics of an item and comparing those characteristics with prescribed standards.

c. Service. Operations required periodically to keep an item in proper operating condition; i.e., to clean (decontaminate), to preserve, to drain, to paint, or to replenish fuel, lubricants, hydraulic fluids, or compressed air supplies.

d. Adjust. To maintain, within prescribed limits, by bringing into proper or exact position, or by setting the operating characteristics to the specified parameters.

e. Align. To adjust specified variable elements of an item to bring about optimum or desired performance.

f. Calibrate. To determine and cause corrections to be made or to be adjusted on instruments or test, measuring, and diagnostic equipments used in precision measurement. Consists of comparisons of two instruments, one of which is a certified standard of known accuracy, to detect and adjust any discrepancy in the accuracy of the instrument being compared.

g. Install. The act of emplacing, seating, or fixing into position an item, part, or module (component or assembly) in a manner to allow the proper functioning of the equipment or system.

h. Replace. The act of substituting a serviceable like type part, subassembly, or module (component or assembly) for an unserviceable counterpart.

i. Repair. The application of maintenance services (inspect, test, service, adjust, align, calibrate, replace) or other maintenance actions (welding, grinding, riveting, straightening, facing, remachining, or resurfacing) to restore serviceability to an item by correcting specific damage, fault, malfunction, or failure in a part, subassembly, module (component or assembly), end item, or system.

j. Overhaul. That maintenance effort (service/action) necessary to restore an item to a completely serviceable/operational condition as prescribed by maintenance standards (i.e., DMWR) in appropriate

technical publications. Overhaul is normally the highest degree of maintenance performed by the Army. Overhaul does not normally return an item to like new condition.

k. *Rebuild.* Consists of those services/actions necessary for the restoration of unserviceable equipment to a like new condition in accordance with original manufacturing standards. Rebuild is the highest degree of materiel maintenance applied to Army equipment. The rebuild operation includes the act of returning to zero those age measurements (hours, miles, etc.) considered in classifying Army equipments/components.

B-3. COLUMN ENTRIES.

a. *Column 1, Group Number.* Column 1 lists group numbers, the purpose of which is to identify components, assemblies, subassemblies, and modules with the next higher assembly.

b. *Column 2, Component/Assembly.* Column 2 contains the noun names of components, assemblies, subassemblies, and modules for which maintenance is authorized.

c. *Column 3, Maintenance Function.* Column 3 lists the functions to be performed on the item listed in column 2. When items are listed without maintenance functions, it is solely for the purpose of having the group numbers in the MAC and RPSTL coincide.

d. *Column 4, Maintenance Category.* Column 4 specifies, by the listing of a "worktime" figure in the appropriate subcolumn(s), the lowest level of maintenance authorized to perform the function listed in column 3. This figure represents the active time required to perform that maintenance function at the indicated category of maintenance. If the number or complexity of the tasks within the listed maintenance function vary at different maintenance categories, appropriate "worktime" figures will be shown for each category. The number of task-hours specified by the "worktime" figure represents the average time required to restore an item (assembly, subassembly, component, module, end item, or system) to a serviceable condition under typical field operating conditions. This time includes preparation time, troubleshooting time, and quality assurance/quality control time in addition to the time required to perform the specific tasks identified for the maintenance functions authorized in the maintenance allocation chart. Subcolumns of column 4 are as follows:

C Operator/Crew

O Organizational

F Direct Support

H General Support

D Depot

e. *Column 5, Tools and Equipment.* Column 5 specifies by code, those common tool sets (not individual tools) and special tools, test, and support equipment required to perform the designated function.

f. *Column 6, Remarks.* Column 6 contains an alphabetic code which leads to the remark in Section IV, Remarks, which is pertinent to the item opposite the particular code.

B-4. TOOL AND TEST EQUIPMENT REQUIREMENTS (SECTION III).

- a. *Tool or Test Equipment Reference Code.* The numbers in this column coincide with the numbers used in the tools and equipment column of the MAC. The numbers indicate the applicable tool or test equipment for the maintenance functions.
- b. *Maintenance Category.* The codes in this column indicate the maintenance category allocated the tool or test equipment.
- c. *Nomenclature.* This column lists the noun name and nomenclature of the tools and test equipment required to perform the maintenance functions.
- d. *National/NATO Stock Number.* This column lists the National/NATO stock number of the specific tool or test equipment.
- e. *Tool Number.* This column lists the manufacturer's part number of the tool followed by the Federal Supply Code for manufacturers (5-digit) in parentheses.

B-5. REMARKS (SECTION IV).

- a. *Reference Code.* This code refers to the appropriate item in Section II, Column 6.
- b. *Remarks.* This column provides the required explanatory information necessary to clarify items appearing in Section II.

Section II. MAINTENANCE ALLOCATION CHART
FOR
PULSE SIGNAL GENERATOR SG-1205(V)1/U

(1) Group Number	(2) Component/ Assembly	(3) Maintenance Function	(4) Maintenance Category					(5) Tools and Equipment	(6) Remarks
			C	O	F	H	D		
0 0	PULSE SIGNAL GENERATOR SG-1205(V)1/U	Inspect	0.1						
		Inspect		0.3				1	
		Test	0.1						
		Test				2.0	2.0	2,3,4,5,6,7,8,9,10, 11,12,13,14	A B
0 1	FRONT PANEL ASSEMBLY	Service	0.1						
		Service		0.8				1	
		Aline				3.0	3.0	2,3,4,5,6,8,9,10, 11,12,13,14	C D B
0 2	REAR PANEL ASSEMBLY	Repair		0.5				1	
		Repair				1.5		2,3,6	
		Repair					3.5	2,3,4,5,6,7,8,9, 10,11,12,13,14	
0 3	CHASSIS SUBASSEMBLY	Repair				0.8		2,3,6	E
0 3 0 1	MAIN PCB ASSEMBLY	Remove/Install				1.0		2,3	
		Repair				0.6		2,3,6	F
0 4	OUTPUT AMPLIFIER ASSEMBLY	Repair				1.0		2,3,6	F
0 4 0 1	SHIELD ASSEMBLY	Replace				0.5		2,3	
		Repair				0.8		2,3,6	G
0 4 0 1	SHIELD ASSEMBLY	Remove/Install				0.3		2,3	
		Repair				0.3		2,3,6	F

**Section III. TOOL AND TEST EQUIPMENT REQUIREMENTS
FOR
PULSE SIGNAL GENERATOR SG-1205(V)1/U**

Tool or Test Equipment Ref Code	Maintenance Category	Nomenclature	National/NATO Stock Number	Tool Number
1	0	TOOL KIT, ELECTRONIC EQUIPMENT TK-101/G	5180-00-064-5178	
2	H, D	TOOL KIT, ELECTRONIC EQUIPMENT TK-100/G	5180-00-605-0079	
3	H, D	TOOL KIT, ELECTRONIC EQUIPMENT TK-105/G	5180-00-610-8177	
4	H, D	OSCILLOSCOPE 60 MHz GENERAL PURPOSE PLUG-IN TEK 5440		
5	H, D	AMPLIFIER DUAL TRACE TEK 5A48	4931-01-008-1480	
6	H, D	TIME BASE DELAY TEK 5B42	4931-01-008-1479	
7	H, D	COUNTER, ELECTRONIC HP 5345A	6625-00-531-4752	
8	H, D	VOLTMETER, DIGITAL HP 3490A WITH K25-3490A PROBE		
9	H, D	GENERATOR, PULSE HP214A	6625-00-682-7452	
10	H, D	VARIAC		
11	H, D	50-OHM/25-WATT LOAD		
12	H, D	50-OHM/5-WATT LOAD		
13	H, D	50-OHM COAXIAL CABLE, 3-FT		
14	H, D	50-OHM 10 X ATTENUATOR 5 WATT		

Section IV. REMARKS

Reference Code	Remarks
A	Operational test.
B	If SG-1205(V)1/U is in storage for more than 6 months, depot is required to conduct full performance test of unit before deployment to field. If unit fails testing, it must be repaired at depot before deployment.
C	Lamps, fuses, and knobs are replaced at the organizational level.
D	Repair is by replacement of the next lower tier components/assemblies/subassemblies.
E	Repair is by replacement of repetition rate switch assembly, delay/advance switch assembly, width switch assembly, amplitude switch assembly, and other front panel assembly piece parts.
F	Repair is by replacement of piece parts.
G	Repair is by replacement of auxiliary drivers pcb assembly, cathode pcb assembly, and other output amplifier assembly piece parts and repair of shield assembly by replacement of piece parts.

APPENDIX E EXPENDABLE SUPPLIES AND MATERIALS LIST

Section I. INTRODUCTION

E-1. SCOPE.

This appendix lists expendable supplies and materials you will need to operate and maintain the signal generator. These items are authorized to you by CTA 50-970, Expendable/Durable Items (Except Medical, Class V, Repair Parts, and Heraldic Items).

E-2. EXPLANATION OF COLUMNS.

a. Column (1) - Item Number. This number is assigned to the entry in the listing and is referenced in the narrative instructions to identify the material; e.g., "Use cleaning compound, item 5, App. E".

b. Column (2) - Level. This column identifies the lowest level of maintenance that requires the listed item.

- C - Operator/Crew
- O - Organizational Maintenance
- F - Direct Support Maintenance
- H - General Support Maintenance

c. Column (3) - National Stock Number. This is the national stock number assigned to the item; use it to request or requisition the item.

d. Column (4) - Description. Indicates the federal item name and, if required, a description to identify the item. The last line for each item indicates the Federal Supply Code for Manufacturer (FSCM) in parentheses followed by the part number.

e. Column (5) - U/M (Unit of Measure). Indicates the measure used in performing the actual maintenance function. This measure is expressed by a two-character alphabetical abbreviation; e.g., ea, in., pr. If the unit of measure differs from the unit of issue, requisition the lowest unit of issue that will satisfy your requirements.

Section II. EXPENDABLE SUPPLIES AND MATERIALS LIST

(1) ITEM NO.	(2) LEVEL	(3) NATIONAL STOCK NUMBER	(4) DESCRIPTION	(5) U/M
1	O	6810-01-382-2904	ALCOHOL, ISOPROPYL, 1.01 FLUID OZ, BOTTLE, ASTM D 770 (81346)	BX
2	C	8020-00-205-6512	BRUSH, SASH (96906)	EA
3	C	8305-00-267-3015	CLOTH, CHEESECLOTH, COTTON, LINTLESS, CCC-C-440, TYPE 11, CLASS 2 (81248)	YD
4	C		DETERGENT, MILD, LIQUID	OZ

GLOSSARY-1

Section I. ABBREVIATIONS

MTOE	Modified Table of Organization and Equipment
PMCS	Preventive Maintenance Checks and Services
TMDE	Test, Measurement, and Diagnostic Equipment

Section II. DEFINITION OF UNUSUAL TERMS

Aberration - Something that departs from the standard or normal state.

Jitter - Instability of a signal. Used to describe minor variations in a signal reproduced on the screen of a cathode-ray tube.

SUBJECT INDEX

Subject	Paragraph, Figure, Table Number	Page
A		
Air Filter, Replace	3-14	3-12
B		
Basic Operation	2-6.b	2-12
C		
Checking Unpacked Equipment	3-4.b	3-2
Common Tools and Equipment	3-1	3-1
Consolidated Index of Army Publications and Blank Forms	1-2	1-1
Controls and Indicators		
Operator's	2-2	2-1
	F2-1	2-2
	T2-1	2-3
D		
Destruction of Army Materiel to Prevent Enemy Use	1-4	1-2
E		
Equipment Characteristics, Capabilities, and Features	1-10	1-2
Equipment Data	1-12	1-4
Equipment Inspection and Maintenance Worksheet (DA Form 2404)	F2-2	2-8
External Triggering	2-6.d	2-16
F		
Front Panel Control Knobs		
Replace	3-13	3-10
Fuse		
Replace	3-12	3-9
G		
Gated Output	2-6.f	2-16

I

Initial Adjustments and Daily Checks	2-5	2-11
--	-----	------

L

Location and Description of Major Components	1-11	1-3
--	------	-----

M

Maintenance Forms and Records	1-2	1-1
Manual Triggering	2-6.e	2-16
Multiple Pulse Output	2-6.a(2)	2-12
Connections	F2-3	2-13

N

Nomenclature Cross-Reference List	1-9	1-2
---	-----	-----

O

Operator Preventive Maintenance Checks and Services	T2-2	2-9
Operators Controls and Indicators	2-2	2-1
	F2-1	2-2
	T2-1	2-3
Operating Procedures	2-6	2-12
Basic Operation	2-6.b	2-12
External Triggering	2-6.d	2-16
Gated Output	2-6.f	2-16
Manual Triggering	2-6.e	2-16
Output Connections	2-6.a	2-12
Sync Output	2-6.c	2-16
Operation in Dusty or Sandy Areas	2-8	2-17
Operation in Extreme Heat...	2-7	2-17
Operation in Rainy or Humid Conditions	2-9	2-17
Operational Test	3-11	3-8
Organizational Preventive Maintenance Checks and Services Monthly Schedule	T3-1	3-4
Output Connections	2-6.a	2-12
Multiple Pulse Output	2-6.a(2)	2-12
Output Termination	2-6.a(1)	2-12
Output Termination	2-6.a(1)	2-12

P

PMCS Procedures, Operator	2-4	2-5
	T2-2	2-9
Explanation of Columns	2-4.d	2-6
Preventive Maintenance Checks and Services	2-4.c	2-6
Routine Checks and Services.	2-4.b	2-6
Tools, Materials and Equipment Required for Preventive Maintenance	2-4.a	2-5

PMCS Procedures, Organizational	3-7	3-3
	T3-1	3-4
Item No	3-7.a(1)	3-3
Item to be inspected	3-7.a(2)	3-3
Procedures	3-7.a(3)	3-3
Preliminary Servicing and Adjustment of Equipment	3-5	3-2
Preparation for Storage or Shipment	1-5	1-2
	3-15	3-13
Pulse Signal Generator SG-1205(V)1/U..	F1-1	1-0
Block Diagram	F1-2	1-6

Q

Quality Assurance/Quality Control (QA/QC)	1-6	1-2
---	-----	-----

R

Repair Parts	3-3	3-1
Reporting Equipment improvement Recommendations (EIR)	1-7	1-2

S

Safety, Care, and Handling	1-12	1-5
Scope	1-1	1-1
Service Upon Receipt of Material	3-4	3-2
Checking Unpacked Equipment	3-4.b	3-2
Unpacking	3-4.a	3-2
Special Tools, TMDE, and Support Equipment	3-2	3-1
Symptom Index		3-5
Sync Output	2-6.c	2-16

T

Troubleshooting		3-5
Symptom Index		3-5
Troubleshooting Table	3-10	3-6
	T3-2	3-7
Using the Troubleshooting Table	3-9	3-6
Troubleshooting Table	3-10	3-6
Types of Storage	3-16	3-13

U

Using the Troubleshooting Table	3-9	3-6
Unpacking	3-4.a	3-2

W

Warranty Information	1-8	1-2
--------------------------------	-----	-----

By Order of the Secretary of the Army:

Official:

JOHN A. WICKHAM JR.
General, United States Army
Chief of Staff

ROBERT M. JOYCE
Major General, United States Army
The Adjutant General

Distribution:

To be distributed in accordance with special list.

These are the instructions for sending an electronic 2028

The following format must be used if submitting an electronic 2028. The subject line must be exactly the same and all fields must be included; however only the following fields are mandatory: 1, 3, 4, 5, 6, 7, 8, 9, 10, 13, 15, 16, 17, and 27.

From: "Whomever" <whomever@wherever.army.mil>

To: 2028@redstone.army.mil

Subject: DA Form 2028

1. **From:** Joe Smith
2. **Unit:** home
3. **Address:** 4300 Park
4. **City:** Hometown
5. **St:** MO
6. **Zip:** 77777
7. **Date Sent:** 19-OCT-93
8. **Pub no:** 55-2840-229-23
9. **Pub Title:** TM
10. **Publication Date:** 04-JUL-85
11. **Change Number:** 7
12. **Submitter Rank:** MSG
13. **Submitter FName:** Joe
14. **Submitter MName:** T
15. **Submitter LName:** Smith
16. **Submitter Phone:** 123-123-1234
17. **Problem:** 1
18. **Page:** 2
19. **Paragraph:** 3
20. **Line:** 4
21. **NSN:** 5
22. **Reference:** 6
23. **Figure:** 7
24. **Table:** 8
25. **Item:** 9
26. **Total:** 123
27. **Text:**

This is the text for the problem below line 27.

TO: (Forward direct to addressee listed in publication) Commander, U.S. Army Aviation and Missile Command ATTN: AMSAM-MMC-MA-NP Redstone Arsenal, 35898	FROM: (Activity and location) (Include ZIP Code) MSG, Jane Q. Doe 1234 Any Street Nowhere Town, AL 34565	DATE 8/30/02
---	--	------------------------

PART II - REPAIR PARTS AND SPECIAL TOOL LISTS AND SUPPLY CATALOGS/SUPPLY MANUALS

PUBLICATION NUMBER			DATE	TITLE				
PAGE NO.	COLM NO.	LINE NO.	NATIONAL STOCK NUMBER	REFERENCE NO.	FIGURE NO.	ITEM NO.	TOTAL NO. OF MAJOR ITEMS SUPPORTED	RECOMMENDED ACTION

PART III - REMARKS (Any general remarks, corrections, or suggestions for improvement of publications and blank forms. Additional blank sheets may be used if more space is needed.)

EXAMPLE

TYPED NAME, GRADE OR TITLE MSG, Jane Q. Doe, SFC	TELEPHONE EXCHANGE/AUTOVON, PLUS EXTENSION 788-1234	SIGNATURE
---	--	-----------

RECOMMENDED CHANGES TO PUBLICATIONS AND BLANK FORMS For use of this form, see AR 25-30; the proponent agency is ODISC4.	Use Part II (reverse) for Repair Parts and Special Tool Lists (RPSTL) and Supply Catalogs/Supply Manuals (SC/SM)	DATE
---	--	------

TO: (Forward to proponent of publication or form)(Include ZIP Code)	FROM: (Activity and location)(Include ZIP Code)
---	---

PART 1 - ALL PUBLICATIONS (EXCEPT RPSTL AND SC/SM) AND BLANK FORMS

PUBLICATION/FORM NUMBER	DATE	TITLE
-------------------------	------	-------

ITEM NO.	PAGE NO.	PARA-GRAPH	LINE NO. *	FIGURE NO.	TABLE NO.	RECOMMENDED CHANGES AND REASON

** Reference to line numbers within the paragraph or subparagraph.*

TYPED NAME, GRADE OR TITLE	TELEPHONE EXCHANGE/ AUTOVON, PLUS EXTENSION	SIGNATURE
----------------------------	--	-----------

TO: (Forward direct to addressee listed in publication)	FROM: (Activity and location) (Include ZIP Code)	DATE
--	---	-------------

PART II - REPAIR PARTS AND SPECIAL TOOL LISTS AND SUPPLY CATALOGS/SUPPLY MANUALS

PUBLICATION NUMBER	DATE	TITLE
--------------------	------	-------

PAGE NO.	COLM NO.	LINE NO.	NATIONAL STOCK NUMBER	REFERENCE NO.	FIGURE NO.	ITEM NO.	TOTAL NO. OF MAJOR ITEMS SUPPORTED	RECOMMENDED ACTION

PART III - REMARKS (Any general remarks or recommendations, or suggestions for improvement of publications and blank forms. Additional blank sheets may be used if more space is needed.)

TYPED NAME, GRADE OR TITLE	TELEPHONE EXCHANGE/AUTOVON, PLUS EXTENSION	SIGNATURE
----------------------------	--	-----------

RECOMMENDED CHANGES TO PUBLICATIONS AND BLANK FORMS For use of this form, see AR 25-30; the proponent agency is ODISC4.	Use Part II (reverse) for Repair Parts and Special Tool Lists (RPSTL) and Supply Catalogs/Supply Manuals (SC/SM)	DATE
---	--	------

TO: (Forward to proponent of publication or form)(Include ZIP Code)	FROM: (Activity and location)(Include ZIP Code)
---	---

PART 1 - ALL PUBLICATIONS (EXCEPT RPSTL AND SC/SM) AND BLANK FORMS

PUBLICATION/FORM NUMBER	DATE	TITLE
-------------------------	------	-------

ITEM NO.	PAGE NO.	PARA-GRAPH	LINE NO. *	FIGURE NO.	TABLE NO.	RECOMMENDED CHANGES AND REASON

** Reference to line numbers within the paragraph or subparagraph.*

TYPED NAME, GRADE OR TITLE	TELEPHONE EXCHANGE/ AUTOVON, PLUS EXTENSION	SIGNATURE
----------------------------	--	-----------

TO: (Forward direct to addressee listed in publication)	FROM: (Activity and location) (Include ZIP Code)	DATE
--	---	-------------

PART II - REPAIR PARTS AND SPECIAL TOOL LISTS AND SUPPLY CATALOGS/SUPPLY MANUALS

PUBLICATION NUMBER	DATE	TITLE
--------------------	------	-------

PAGE NO.	COLM NO.	LINE NO.	NATIONAL STOCK NUMBER	REFERENCE NO.	FIGURE NO.	ITEM NO.	TOTAL NO. OF MAJOR ITEMS SUPPORTED	RECOMMENDED ACTION

PART III - REMARKS (Any general remarks or recommendations, or suggestions for improvement of publications and blank forms. Additional blank sheets may be used if more space is needed.)

TYPED NAME, GRADE OR TITLE	TELEPHONE EXCHANGE/AUTOVON, PLUS EXTENSION	SIGNATURE
----------------------------	--	-----------

RECOMMENDED CHANGES TO PUBLICATIONS AND BLANK FORMS For use of this form, see AR 25-30; the proponent agency is ODISC4.	Use Part II (reverse) for Repair Parts and Special Tool Lists (RPSTL) and Supply Catalogs/Supply Manuals (SC/SM)	DATE
---	--	------

TO: (Forward to proponent of publication or form)(Include ZIP Code)	FROM: (Activity and location)(Include ZIP Code)
---	---

PART 1 - ALL PUBLICATIONS (EXCEPT RPSTL AND SC/SM) AND BLANK FORMS

PUBLICATION/FORM NUMBER	DATE	TITLE
-------------------------	------	-------

ITEM NO.	PAGE NO.	PARA-GRAPH	LINE NO. *	FIGURE NO.	TABLE NO.	RECOMMENDED CHANGES AND REASON

** Reference to line numbers within the paragraph or subparagraph.*

TYPED NAME, GRADE OR TITLE	TELEPHONE EXCHANGE/ AUTOVON, PLUS EXTENSION	SIGNATURE
----------------------------	--	-----------

TO: (Forward direct to addressee listed in publication)	FROM: (Activity and location) (Include ZIP Code)	DATE
--	---	-------------

PART II - REPAIR PARTS AND SPECIAL TOOL LISTS AND SUPPLY CATALOGS/SUPPLY MANUALS

PUBLICATION NUMBER	DATE	TITLE
--------------------	------	-------

PAGE NO.	COLM NO.	LINE NO.	NATIONAL STOCK NUMBER	REFERENCE NO.	FIGURE NO.	ITEM NO.	TOTAL NO. OF MAJOR ITEMS SUPPORTED	RECOMMENDED ACTION

PART III - REMARKS (Any general remarks or recommendations, or suggestions for improvement of publications and blank forms. Additional blank sheets may be used if more space is needed.)

TYPED NAME, GRADE OR TITLE	TELEPHONE EXCHANGE/AUTOVON, PLUS EXTENSION	SIGNATURE
----------------------------	--	-----------

